

Machine dimensions

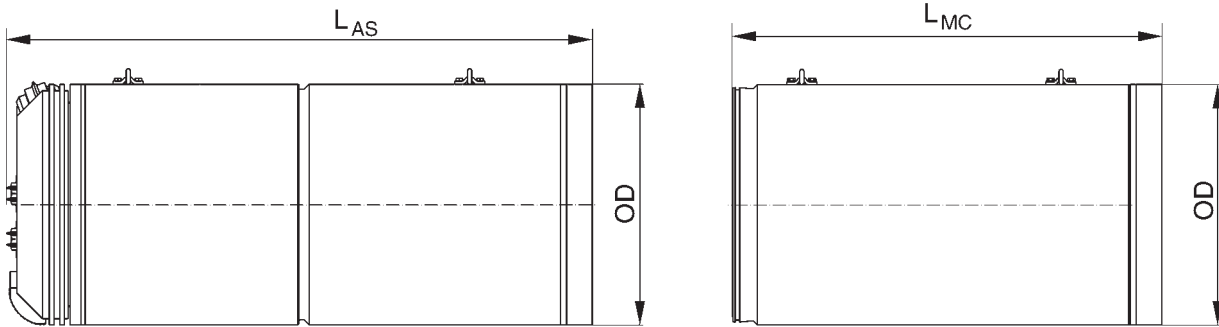

			EPB1500AE	EPB1600AE	EPB1800AE	EPB2000AE	EPB2200AE	EPB2400AE	EPB2500AE
Outer Diameter	OD	mm	1 810	1 970	2 150	2 425	2 725	3 025	3 125
Length artic. shield	L_{AS}	mm	4 800	4 800	5 100	5 100	5 250	6 000	6 000
Length machine can	L_{MC}	mm	-	-	-	-	-	-	-
Max. single weight	W	kg	17 000	19 000	30 000	32 000	35 000	48 000	50 000

Shaft dimensions

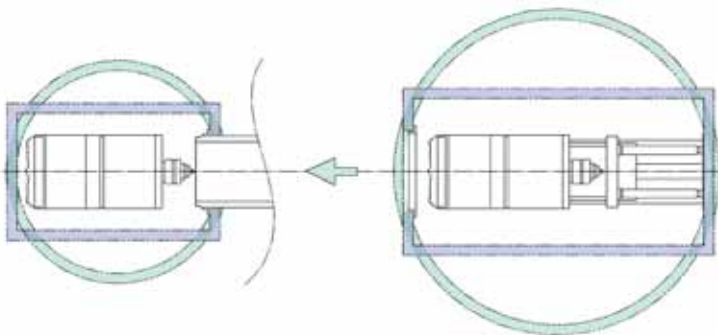

			EPB1500AE	EPB1600AE	EPB1800AE	EPB2000AE	EPB2200AE	EPB2400AE	EPB2500AE
Launch Shaft Main jacking station	Pipe length 2 500 mm	Shaft size	Shaft size	Shaft size	Shaft size	Shaft size	Shaft size	Shaft size	Shaft size
		$\varnothing = 9.0m$	$\varnothing = 9.0m$	-	-	-	-	-	-
	3 000 mm	3.5m x 9.0m	3.5m x 9.0m	-	-	-	-	-	-
Reception Shaft	L_{AS}	Shaft size	Shaft size	Shaft size	Shaft size	Shaft size	Shaft size	Shaft size	Shaft size
		$\varnothing = 9.5m$	$\varnothing = 9.5m$	$\varnothing = 10.0m$	$\varnothing = 10.0m$	$\varnothing = 10.5m$	$\varnothing = 11.5m$	$\varnothing = 11.5m$	
	Circular	3.5m x 9.5m	3.5m x 9.5m	4.0m x 9.5m	4.5m x 9.5m	5.0m x 10.5m	5.0m x 11.0m	5.0m x 11.0m	
		4 800mm	4 800mm	5 100mm	5 100mm	5 250mm	6 000mm	6 000mm	
		$\varnothing = 6.0m$	$\varnothing = 6.0m$	$\varnothing = 6.5m$	$\varnothing = 6.5m$	$\varnothing = 7.0m$	$\varnothing = 7.5m$	$\varnothing = 7.5m$	
Rectangular	2.5m x 5.5m	3.0m x 5.5m	3.0m x 6.0m	3.5m x 6.0m	4.0m x 6.0m	4.0m x 7.0m	4.5m x 7.0m		

All dimensions according to 15m shaft depth.

Machine type description e.g. AVN ¹⁾ 1800 ²⁾ T ³⁾ B ⁴⁾			
1) Machine type	2) ID of jacking pipe	3) Access to cutting wheel	4) Type of container, power transfer from container to machine
		X = no access	B = electric cable to machine, power pack in machine
		T = central door	C = hydraulic drive from container directly into machine
		A = door above main drive or in top of pressure wall	E = electric cable from container directly into machine
			H = medium voltage supply to machine (> 1000V)

Herrenknecht AG
 77963 Schwanau · Germany
 Tel. +49 (7824) 302 923
 Fax +49 (7824) 302 364
 utility@herrenknecht.de

www.herrenknecht.com

