

JDN OPERATING AND ASSEMBLY INSTRUCTIONS

Hoist

PROFI 25 TI

Serial No.: 3101649-3101650

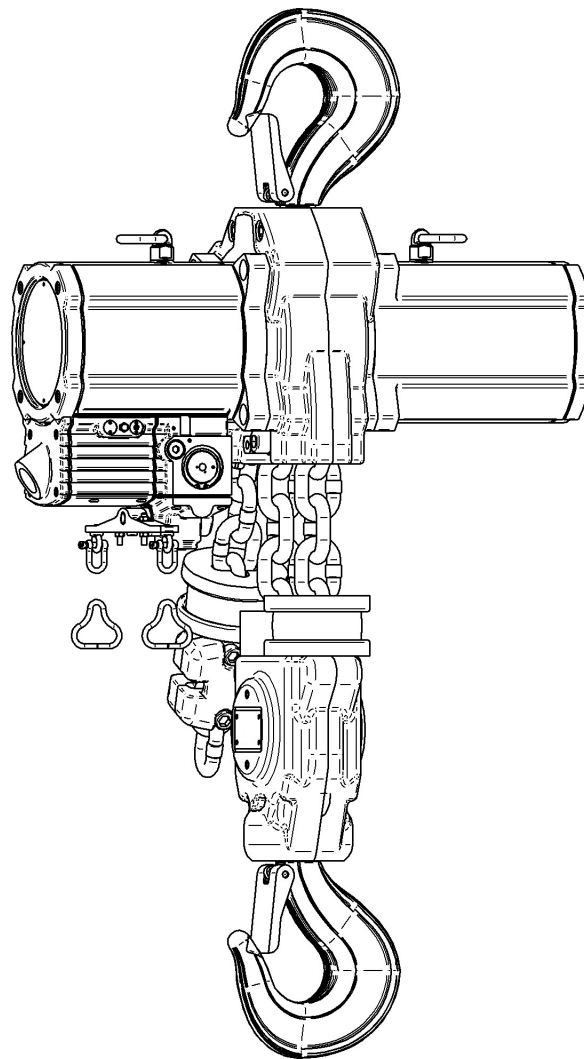

Representation may differ from actual product!

ORIGINAL OPERATING
AND ASSEMBLY INSTRUCTIONS





These operating instructions are a part of the product. Always keep the instructions on site.

The operating instructions are to be read carefully and in their entirety before handling any product. Read the safety precautions in order to avoid injury. Improper use of the product can lead to injury.

Please also note the safety signs on the product. In addition, all local accident prevention regulations and general safety regulations also apply.

Illustrations in these operating instructions are intended for the basic understanding of the product and may deviate from the actual design.

You can find additional representations and tightening torques of screw connections in the spare parts list.

Limitation of liability

All information and instructions in these instructions were compiled in accordance with the applicable standards and regulations, current technological standards as well as many years of experience.

J.D. Neuhaus GmbH & Co. KG assumes no liability for damage due to:

- Non-observance of the instructions
- Inappropriate use
- Use by untrained personnel
- Unauthorised conversions
- Technical changes
- Use of unauthorised spare parts

Copyright protection

All rights reserved by the manufacturer. Neither the operating instructions as a whole nor individual sections may be reproduced, distributed or processed using electronic systems in any form without written permission from J.D. Neuhaus GmbH & Co. KG. All of the brands mentioned in these operating instructions are the property of their respective manufacturers and are hereby acknowledged.

Contact data

If you have questions about handling your product that are not answered in these operating instructions, please contact

J.D. Neuhaus GmbH & Co. KG
Windenstraße 2-4
D-58455 Witten-Heven

Telephone +49 02302 / 208-0
Fax +49 02302 / 208-286
www.jdnngroup.com
e-mail: info@jdnngroup.com

Validity of the operating instructions

These product-specific operating instructions (doc. no. VA049318-10-OM-EN-0319-64-2), edition 03/19, apply exclusively for the product *PROFI 25 TI* with the serial number 3101649-3101650 .

Subject to changes!

Contents

1. User information	7	4.2. Storage conditions	27
1.1. About these operating instructions	7	4.2.1. Breaks in operation	27
1.2. Symbols and Signs	7	4.2.2. Storage	27
1.3. Notes regarding text representation	7	5. Initial operation	29
2. Safety information	9	5.1. Unpacking	29
2.1. General safety instructions	9	5.2. Attach the hoist	29
2.2. Qualification of personnel	9	5.3. Connecting the power supply	30
2.3. Operator obligations	9	5.4. Lubricating the chain	30
3. Product information	11	5.5. Tests before commissioning	30
3.1. Proper use	11	5.5.1. Check control device	31
3.2. Improper use	11	5.5.2. Check direction of movement	31
3.3. Labelling (nameplate)	12	5.5.3. Check the braking function	31
3.4. Module overview	13	5.5.4. Check overload protection	32
3.5. Product description	13	5.5.5. Check lifting limiter	33
3.5.1. Load capacity	13	5.5.6. Check lowering limiter	34
3.5.2. Driving mechanism classification	13	6. Operation	35
3.5.3. Explosion protection classification	14	6.1. Rules for safe operation	35
3.5.4. Vane motor	15	6.2. Attaching the load	36
3.5.5. Motor lubrication	15	6.3. Lifting the load	37
3.5.6. Control	15	6.4. Lowering the load	37
3.5.7. EMERGENCY STOP device	16	6.5. Releasing the load (detaching)	37
3.5.8. Overload protection	16	6.6. Interrupting work	38
3.5.9. Lifting limiter	17	7. Decommissioning	39
3.5.10. Lowering limiter	17	7.1. Disassembly	39
3.5.11. Load hook	18	7.2. Disposal	39
3.5.12. Chain	18	8. Maintenance	41
3.5.13. Dead end chain mount	19	8.1. Inspection and repairs	41
3.6. Emissions	19	8.2. Model for determining the actual use	42
3.6.1. Noise emissions	19	8.3. Maintenance and inspection intervals	44
3.6.2. Oil emissions	19	8.4. Spare parts	46
3.7. Conditions of use	19	8.5. Cleaning and care	46
3.8. Power requirement	20	8.6. Lubricate and grease	46
3.8.1. Connections	20	8.6.1. Operating materials	46
3.8.2. Pressure	20	8.6.2. Lubricating the chain	47
3.8.3. Volume	20	8.6.3. Re-lubricate the lifting motor	48
3.8.4. Quality of the compressed air	21	8.7. Check control device	50
3.9. Operating materials	21	8.8. Check direction of movement	50
3.10. Explosion protection	22	8.9. Check the braking function	50
3.11. CE-marking	26	8.10. Check the buffer	51
3.12. Spare parts	26	8.11. Check lifting limiter	51
4. Transport and storage	27	8.12. Check lowering limiter	52
4.1. Safe transportation	27	8.13. Check overload protection	52
		8.14. Check chain	53
		8.15. Check chain sprocket	54
		8.16. Check the chain guide and hook mount	54
		8.17. Check the hook, shackle and eyelets	55

CONTENTS

8.18. Check silencer	56
8.19. Check lifting motor	56
8.20. Replace chain	58
9. Faults, causes and remedies	61
A. Technical data	63
B. Dimensions	64

1. User information

1.1. About these operating instructions

These operating instructions should make it easy for you to get to know your product *PROFI 25 TI* and to take advantage of the intended application possibilities.

These operating instructions contain important information to be able to operate your *PROFI 25 TI* safely, properly and efficiently. Your observance helps to avoid dangers, reduced repair costs and downtimes and to achieve the specified service life of the product.

1.2. Symbols and Signs

Safety instructions are classified in four stages in these operating instructions:



DANGER

Indicates an imminently hazardous situation that will result in death or serious injury if not avoided.



WARNING

Indicates a possibly hazardous situation that may result in death or serious injury if not avoided.



CAUTION

Indicates a potentially hazardous situation that may result in minor or moderate injury if not avoided.

NOTICE

Indicates a potentially hazardous situation that may lead to property and environmental damage if not avoided.

1.3. Notes regarding text representation

- ▶ Instructions for behaviour
- Listings without specified sequence
- ↔ Reference to other sections in these operation instructions or applicable documents

2. Safety information

2.1. General safety instructions

Your product *PROFI 25 TI* is built according to current technological standards and the recognised technical safety regulations. Nevertheless, dangers to life and limb of the user or third parties or impairments to their product and other property may result if the safety rules are disregarded during the product's use.

The personnel commissioned with activities on your product *PROFI 25 TI* must have read and understood the operating instructions prior to beginning work, in particular here the chapter "Rules for safe operation" (↔ page 35). In particular, this applies to personnel who only use your product occasionally, such as for maintenance or retrofitting work.

In the Federal Republic of Germany, professional association accident prevention regulations and rules as well as state health and safety regulations are to be observed when operating hoists, in particular

- BGV A1 accident prevention regulation "Principles of prevention"
- BGV D8 accident prevention regulation "Winches, hoists and towing devices"
- BGR 258 professional association regulation "Operation of load lifting appliances in hoist operation"

are to be observed by the operator in their respective valid version and the prescribed tests are to be initiated by the operator (↔ "Principles for testing cranes" BGG 905 (ZH 1/27)).

To document the tests, we recommend the "Test book for cranes" BGG 943 (ZH 1/29) from the professional associations. When operating the product in areas with a potentially explosive atmosphere, the relevant explosion protection regulations are to be observed, such as

- BGR 104 "Explosion protection regulations"
- BGR 132 "Preventing ignition hazards due to electrostatic charges"

In other countries, the corresponding national regulations are to be observed.

When installing your product *PROFI 25 TI* in systems as well as in exceptional cases of use, special regulations may apply.

2.2. Qualification of personnel

The personnel responsible for operation, maintenance, inspection and set-up work must be competent or be instructed by a competent person before beginning work.

Due to their professional training and experience, competent persons have sufficient knowledge about the product *PROFI 25 TI*. They are familiar with the relevant health and safety regulations as well as accident prevention regulations to the extent that they can assess the safe working condition of your product.

- ▶ Observe the operating instructions for your workplace.
- ▶ Follow the accident prevention regulations.
- ▶ Receive instruction on dealing with hazardous materials.
- ▶ Follow the safety guidelines listed in the operating instructions.

2.3. Operator obligations

The operator of the product *PROFI 25 TI* is obliged to ensure a safe and hazard-free operation. This can be achieved through the following measures:

- ▶ providing operating instructions on site at all times,
- ▶ carrying out regular training sessions,
- ▶ carrying out periodic inspections,
- ▶ regularly checking personnel work in a safety and hazard-conscious manner.
- ▶ If a load is lifted by several hoists, the working routine must be stipulated by the contractor and supervised by a supervisor.

The operator of the product *PROFI 25 TI* is responsible for regularly and properly keeping a test book.

- ▶ Adhere to the prescribed maintenance intervals.
- ▶ Only use the product for work that is described as intended.
- ▶ Observe the conditions of use described in these instructions for your product.

3. Product information

3.1. Proper use

Your product *PROFI 25 TI* is designed for lifting and lowering loads in the range of the rated load capacity with a vertically arranged chain.

Your product is also suitable for pulling loads horizontally.

In combination with a trolley, your hoist is also suitable for overhead horizontal movement of loads.

Please observe the following national legal provisions. Any other or exceeding use is considered improper. J.D. Neuhaus GmbH & Co. KG assumes no liability for damage resulting from this improper use. The risk is borne solely by the user.

Proper use also includes the observance of the operating instructions and compliance with the inspection and maintenance conditions.

3.2. Improper use

Among others, the following are considered improper uses

- Changing load capacities with the load position: Your product is not equipped with a load capacity display, which is why it may only be used in such cases where the load capacity does not change with the load position
- Exceeding the load capacity
- Breaking free or towing loads
- Load the hook at the tip
- Catching falling loads
- Transporting people
- Jog controls
- For ongoing motion, switch in the opposite direction
- Starting lifting and lowering limiter under normal operating conditions
- In the upper or lower limit position of the load hook, keep the chain taught in the area of the central part
- Transport of changing masses
- Oblique pulling

Definition of oblique pulling (↔ Figure 1)

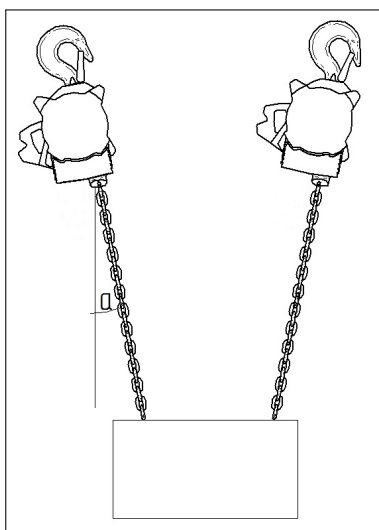

Figure 1: Oblique pulling

Oblique pulling is the deviation from the vertical position of the load chain and the chain hoist in the straight course of the force line between the point of application of force of the load on the load hook and the suspension on the carrying structure ($\alpha \neq 0^\circ$).

Using special safety precautions that are appropriate for the respective situation, your product *PROFI 25 TI* can be used for diagonal pull. In the process, a chain box may not be used, as the chain could fall out here or become knotted. Please contact us if necessary.

For other foreseeable misuses:
↔ *Rules for safe operation*, page 35

Your product *PROFI 25 TI* may not be used in the following areas:

- critical areas in nuclear plants
- over acid baths or systems with aggressive substances
- in areas where there are organic acids
- in areas outside of the permissible ambient temperatures

3.3. Labelling (nameplate)

You will find a nameplate on your product *PROFI 25 TI* for an exact identification.

The nameplate of the product *PROFI 25 TI* (Figure 2) with all of the important information is located on the housing cover of the hoist motor.

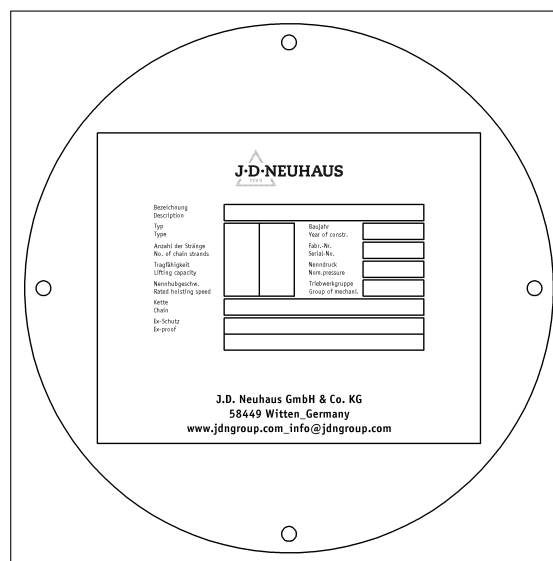

Figure 2: Nameplate *PROFI 25 TI*

3.4. Module overview

Your product *PROFI 25 TI* consists of the following main modules (↔ Figure 3):

1. Gear mechanism
2. Motor with integrated brake
3. Control valve
4. Support hook / Load eye
5. Chain
6. Bottom block
7. Load hook / clevis
8. Middle section

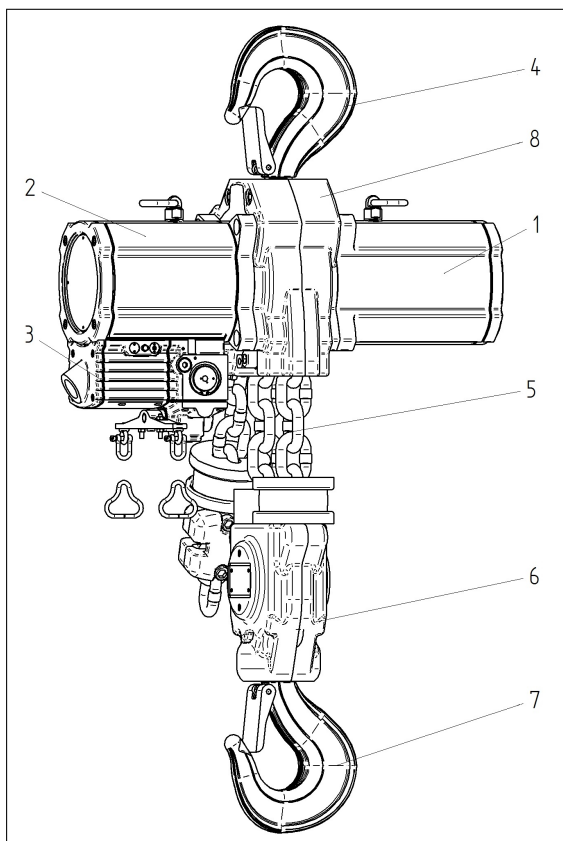

Figure 3: Module overview

3.5. Product description

In the following, you will receive a description of your product *PROFI 25 TI* and its modules or components. You will find other technical data in the appendix.

3.5.1. Load capacity

The permissible load capacity of your product *PROFI 25 TI* is 25t.

3.5.2. Driving mechanism classification

Your *PROFI 25 TI* corresponds to the driving mechanism classification M3 / 1Bm according to ISO 4301 / FEM 9.511.

The daily running time and the load spectrum determine the classification.

A safe operating period only corresponds to the theoretical use if the group classification correlates with the actual operation of the hoist. Deviations of the actual mode of operation from the underlying mode of operation extend or shorten the safe operating period.

The product has a limited service life. Special tests are required after the theoretical utilisation has expired.

3.5.3. Explosion protection classification

Your product *PROFI 25 TI* is marked according to EC directive 2014/34/EU and DIN EN 1127-1 as follows:

- ⊕ II 3 GD IIB T4(X)
- ⊕ II 2 GD IIA T4(X)

The additional marking “X” refers to the explosion protection in the operating instructions.

⊕ **II 3 GD IIB T4(X)**: Your product *PROFI 25 TI* is a device in category 3, can be used in general industry, in zone 2 for gases of the explosion groups IIA and IIB with an ignition temperature over 135°C (275°F), provided the substances of hydrogen sulphide and ethylene oxide are excluded.

Your product can also be used in zone 22 for dusts with smouldering temperatures above 210°C (410°F) or ignition temperatures above 203°C (398°F).

Additional label “X”: This mark does not allow use in the event of light alloy metal or other impact sensitive dusts. The permissible ambient temperature range is from -20°C (-4°F) to +70°C (+158°F). With load capacities from 25t, no continuous operation of the hoists is permitted if the ambient temperature exceeds +50°C (+122°F). In these cases, cooling times are to be met so as not to exceed the permissible surface temperatures.

⊕ **II 2 GD IIA T4(X)**: Your product *PROFI 25 TI* is a device in category 2, can be used in general industry, in zones 1 and 2 for gases of the explosion group IIA with an ignition temperature over 135°C (275°F).

Your product can also be used in zones 21 and 22 for dusts with smouldering temperatures above 210°C (410°F) or ignition temperatures above 203°C (398°F).

Additional label “X”: This mark does not allow use in the event of light alloy metal or other impact sensitive dusts. The permissible ambient temperature range is from -20°C (-4°F) to +70°C (+158°F). With load capacities from 25t, no continuous operation of the hoists is permitted if the ambient temperature exceeds +50°C (+122°F). In these cases, cooling times are to be met so as not to exceed the permissible surface temperatures.

For more information about explosion protection
↔ Section 3.10, Page 22

3.5.4. Vane motor

The vane motor (↔ Figure 4) consists of a cylinder liner (1) with two lateral bearing washers and an inner rotor (2).

The rotor is mounted eccentrically in the cylinder liner and is provided with slots (3) for holding the slats (4).

The slots can move freely and are on the inner wall (5) of the cylinder liner. Two slots form a chamber (6).

The incoming compressed air creates a greater force at the leading larger slot surface (4.1) than at the following smaller slot surface (4.2). The rotor's torque results from the difference in force.

The compressed air can again escape when passing through the outlet opening (7). Lubricant chambers (8) are arranged between the vane slots of the rotor. They ensure a continuous motor lubrication (not applicable for mini).

The arrows in the illustration indicate the direction of rotation of the rotor and the corresponding path of the compressed air.

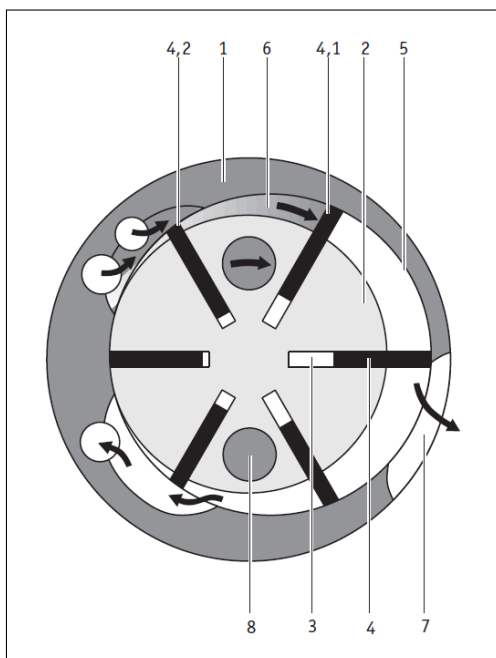

Figure 4: Functioning of the compressed air vane motor

3.5.5. Motor lubrication

The JDN high performance grease contained in the motor allows for operation with oil-free compressed air.

It works over an operating time of about 250 hours and should, however, be replaced as required, but after five years at the latest.

3.5.6. Control

The lifting and lowering motion is controlled directly from the rope control (↔ Figure 5). One-handed sensitive operation is possible. The direction of movement is indicated by arrows.

- ▶ Lifting: Carefully pull on the rope with the green handle cone. The load will be lifted slowly.
- ▶ Pull on the rope harder to increase the lifting speed.
- ▶ Ease up on the rope slightly to reduce the lifting speed.
- ▶ Lowering: Carefully pull on the rope with the yellow handle cone. The load will be lowered slowly.
- ▶ Pull on the end of the rope harder to increase the lowering speed.
- ▶ Ease up on the rope slightly to reduce the lowering speed.

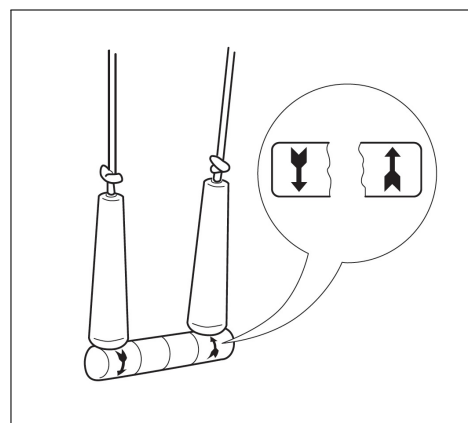

Figure 5: Control

The control system is suitable for use in explosive areas.

All control switches automatically return to the neutral position when released. All movements are stopped instantaneously and the load is securely held in its current position.

3.5.7. EMERGENCY STOP device

The lifting and lowering motion is controlled directly from the rope control.

The control devices of the rope control and the energy-switching part of the control valve on the motor (reversing valve) are positively linked with each other. This connection is designed so that the control valve can be reset to a stable neutral position in cases of emergency. This means that no other EMERGENCY STOP device is necessary.

3.5.8. Overload protection



DANGER

Danger from loads crashing

If the overload protection is set too high, unacceptably high stresses can occur if a load is suspended above the maximum load capacity. There is a danger of the chain and device breaking!

- ▶ Do not transport any overloads
- ▶ Correctly set the overload protection.

In the event of overload, the overload protection switches off the control pressure for lifting. It reacts with a certain load-dependent delay and is set to a limit value of about 125% of the nominal load.

The overload protection is located in the control valve.

After triggering the overload protection, lowering is still possible - the load can be deposited and reduced.

The overload protection can also respond if a load that is to be lifted is approached at full idle speed, even if this is below the set load size.

That is why we recommend making the slack chain taut first before the load is lifted.

3.5.9. Lifting limiter

 WARNING
<p>Danger from chain fracture If the buffers are damaged, unacceptably high loads may act on the chain when starting the lifting limiter. The chain may break.</p> <ul style="list-style-type: none"> ▶ Do not use product ▶ Have product repaired (replace buffer)
NOTICE
<p>The lifting limiter may only be started in cases of emergency. The operator must monitor the load hook movement and stop the lifting movement in due time. Striking the buffer against the housing is to be avoided. This may result in damage to the buffers.</p>

Your product is equipped with a limiter that stops the lifting movement (↔ Figure 6).

In order to achieve a limitation of the lifting movement, a buffer (1) is mounted to the bottom block / load sleeve. If the buffer is moderately deformed in the boundary layer, the overload protection switches the motor off.

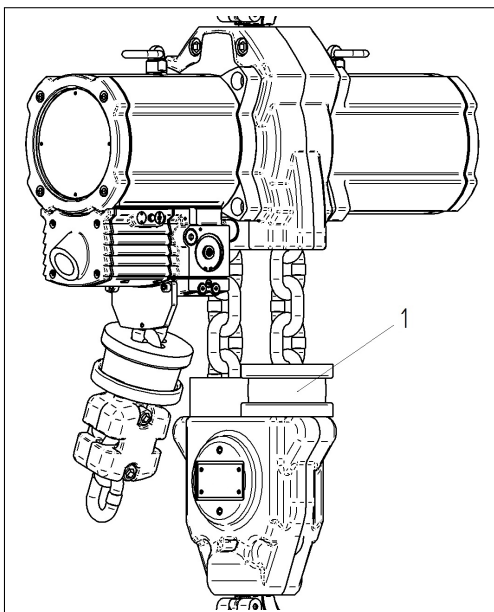



Figure 6: Lifting limiter

3.5.10. Lowering limiter

 WARNING
<p>Danger from chain fracture If the buffer is damaged, unacceptably high loads may act on the chain when starting the lowering limiter. The chain may break.</p> <ul style="list-style-type: none"> ▶ Do not use product ▶ Have product repaired (replace buffer)
NOTICE
<p>The lowering limiter may only be started in cases of emergency. The operator must monitor the load hook movement and stop the lowering movement in due time. Striking the buffer against the housing is to be avoided. This may result in damage to the buffers.</p>

Your product is equipped with a limiter that stops the lowering movement (↔ Figure 7).

In order to achieve this, a buffer (1) is mounted to the empty end of the part of the chain.

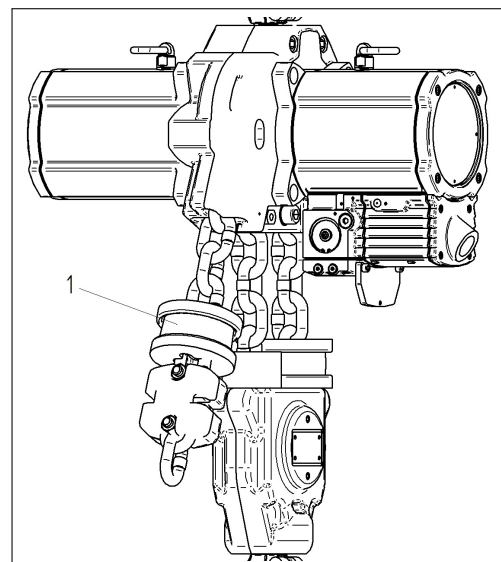

Figure 7: Lowering limiter

3.5.11. Load hook

NOTICE

Load hooks may not be loaded at the top. They may not be directed or annealed. This may result in damage to the load hook.

If the load hook is bent, your product *PROFI 25 TI* must be inspected.

The permissible temperature range is -40°C (-40°F) to +150°C (302°F).

3.5.12. Chain

WARNING

Danger from chain fracture

The fatigue strength of chains is significantly impaired by extreme corrosion (pitting corrosion). In addition, rusty chains result in heavy wear. There is a danger of breakage!

► Do not use rusty chains

WARNING

Danger from chain fracture

Hydrogen-induced embrittlement with subsequent stress corrosion from highly corrosive media (e.g. sea water) may appear on high-strength alloys (e.g. on the chain). There is a danger of breakage!

So-called recombination toxins promote this process. Hydrogen sulphides, cyanide, arsenic compounds and thiocyanates are known for this.

► Protect the chain against strong corrosion

NOTICE

JDN chains are matched in close tolerances to the sprocket. In order to ensure an optimum function of the chain and in order to prevent dangers, only genuine JDN chains may be installed.

Your product *PROFI 25 TI* has 2 falls and the chain size 23,5 x 66.

The chain is manufactured according to DIN EN 818-7. The permissible temperature range is -40°C (-40°F) to +150°C (+302°F).

3.5.13. Dead end chain mount



WARNING

Danger from falling chain

It is important to ensure that the idle chain (unloaded chain end) accumulating on or sagging from the sprocket does not cause any hazard, such as from catching, impacting or falling. There may be hazards from the chain falling if the idle chain is first deposited on a load with a large surface when lifting and then slides off and drops.

- ▶ Ensure that the chain does not get caught, hit anything or fall down.

The last link of the dead end chain mount (unloaded chain end) is attached to the empty strand anchorage (↔ Figure 8 (1)). This serves the purpose that the empty chain strand does not dangle so long and thus cannot lead to the hazardous situations listed above.

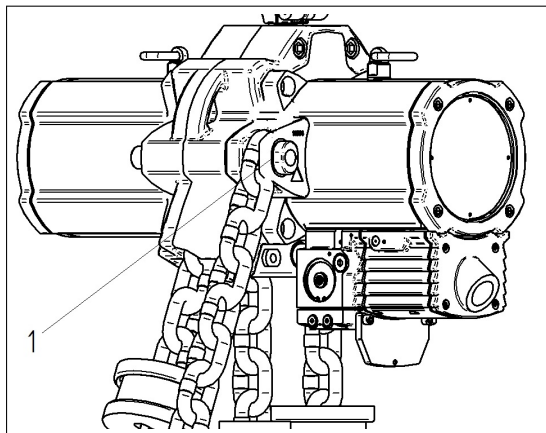

Figure 8: Dead end chain mount

3.6. Emissions

3.6.1. Noise emissions

When lifting the nominal load, the sound pressure level is 78 dB(A). When lowering the nominal load, the sound pressure level is 82 dB(A).

The decrease of the sound pressure level in the hall is about 3 dB(A) per distance doubling.

3.6.2. Oil emissions

When operating with oil lubrication of the motor, small amounts of lubricating oil are discharged into the environment with the exhaust air.

3.7. Conditions of use

Your product *PROFI 25 TI* is very sturdy and requires very little maintenance. It is suitable for applications in explosive areas as well as in areas with increased concentrations of soot, dust, humidity and ambient temperatures from -20°C (-4°F) to +70°C (+158°F), if it is not heated up further due to external influences.

The thermal resistance of the chain and hook is 150°C (302°F).

For stationary use outdoors, you must protect your product against the effects of weather and shorten the maintenance intervals.

Stopping and securing against the wind is required upon reaching a critical wind surge pressure. The critical wind surge pressure depends, among other things, on the mass and shape of the load to be lifted.

3.8. Power requirement

3.8.1. Connections

The connection for the compressed air supply has the size G 1 1/2.

Please use the corresponding hose lines for the selected pressure.

3.8.2. Pressure

WARNING

Danger of explosion

Operating at higher system pressures may result in hazards due to overload.

When operating at lower system pressures, the brake can grind and is therefore subject to very high wear. Inadmissibly high heating may result. The load capacity of the device is reduced. The response of the control system decreases noticeably.

► Comply with the specified pressure.

Your product *PROFI 25 TI* must be operated with a nominal pressure of 6bar (85psi) (see specification on the nameplate).

Air pressure conditions during operation (↔ Figure 9)

The system pressure existing in the line must correspond to the nominal pressure. Higher pressures must be reduced.

After switching on, the adjoining nominal pressure p_1 reduces to the actual pressure p_2 . The extent of the actual pressure p_2 at which the product is operated is dependent on

- the weight of the load **(2)** and the
- direction of movement of the load **(3)**.

When lifting the nominal load (load capacity) at the specified lifting speed, the actual pressure p_2 may at a maximum be 10% below the specified nominal pressure of the hoist (measured immediately before the lifting motor)!

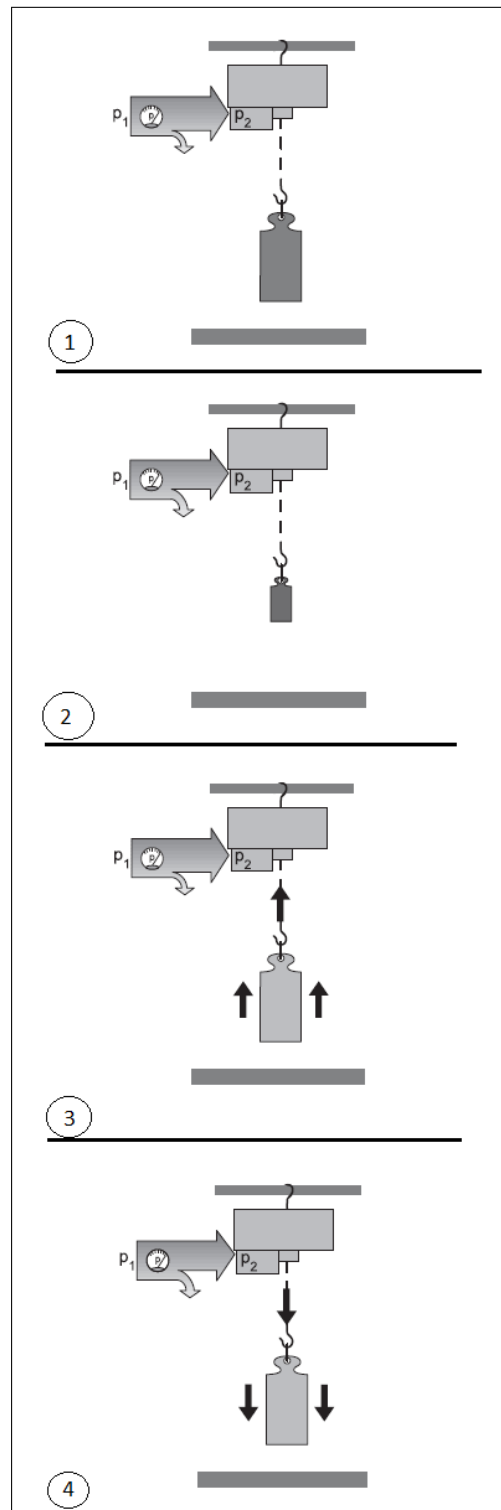

Figure 9: Air pressure conditions during operation

3.8.3. Volume

When lifting the nominal load, the air consumption is $6,5 (230) \frac{m^3}{min} (cfm)$. When lowering the nominal

load, the air consumption is $2,9 (102) \frac{m^3}{min} (cfm)$.

3.8.4. Quality of the compressed air

NOTICE

There is a danger of icing in the motor if there is moist air and ambient temperatures at or below 0°C (32°F)!

You can avoid icing by:

- ▶ Connecting an air dehydrator upstream
- ▶ When using a service unit with an oiler, depending on the moisture content of the compressed air, add an anti-icing agent to the lubricating oil or use an air lubricator (type no. 11900) with an anti-icing additive for the corresponding temperatures.

Your product *PROFI 25 TI* must be operated with a sufficiently clean and dry working air. The working air must meet the following quality requirements:

- Particle size less than $40\mu m$ (1,57mils)
- Particle density smaller than $10 \frac{mg}{m^3}$ (entspricht Class 7 nach ISO 8573-1 : 2001)

To provide a sufficient compressed air quality, we recommend operation with a filter regulator.

The pressure condensation point must be at least 10K below the lowest expected ambient temperature.

Do not operate your product with other gases!

3.9. Operating materials

CAUTION

Danger of skin irritation

Oils and greases may cause skin irritation.

- ▶ Wear protective gloves

NOTICE

Do not mix synthetic oils or greases with mineral oils or greases, as the properties may deteriorate. Also never mix different types of lubricating grease within the synthetic or mineral lubricant groups. When operating with oilers, synthetic lubricants may never be used. Alcohols are not permitted as de-icing agents.

The following operating materials and lubricants are intended for normal environmental influences. In the event of environmental influences that promote wear, please contact J.D. Neuhaus to obtain appropriate information.

Application area	Operating material
Motor lubrication	JDN high performance grease, item no. 11904 (250ml)
Engine lubrication for operation with oiler	Air lubricator "D", kinematic viscosity about $30 \frac{mm^2}{s}$ (cSt) at 40°C, possibly with anti-icing agent
Chain lubrication	Chain oil or vehicle motor oil, kinematic viscosity about $150 \frac{mm^2}{s}$ (cSt) at 40°C, or special lubricant from J.D. Neuhaus. In areas with extreme corrosion potential, such as offshore, a lubricant with a particularly powerful corrosion protection is to be used.
Motor corrosion protection (not applicable if using the JDN high performance grease)	Non-gumming preservative oil with corresponding effective duration
Engine cleaning (not applicable if using the JDN high performance grease)	Pure petroleum
Lubrication for bearings and gearbox (also for open gears)	Lithium-saponified grease, worked penetration 265-295 (0,1mm), base oil viscosity: $190 \frac{mm^2}{s}$ (cSt) at 40°C, dropping point: 180°C, Application temperatures: -20°C to +120°C, Designation according to DIN 51825: KP2K-20, active ingredients: EP additives (to reduce wear) and ageing protection; water-resistant and anti-corrosive

3.10. Explosion protection

The basis for the following information is an expert statement by DMT Gas & Fire Division regarding the use of JDN hoists, trolleys and cranes in potentially explosive areas based on the European directive 94/9/EC ("ATEX 100a"). DMT is accredited for the testing devices and protective systems for proper use in potentially explosive areas.

Load chain To ensure the required earthing, badly rusted chains may no longer be used in zones 1 and 21 as well as in devices of category M2. For, depending on the degree of corrosion, the conductivity of the chain may deteriorate so that it is no longer sufficient.

Hoses Hoses in zone 1 must have a sufficiently low surface resistance of less than $10^9 \Omega$ in order to avoid electrostatic ignition hazards. Otherwise (at $> 10^9 \Omega$) the hoses for explosion groups I, IIA and IIB must be $\leq \varnothing 30mm$ and for explosion group IIC $\leq \varnothing 20mm$ or they must have the evidence that they cannot be dangerously loaded.

Materials for friction and impact hazards Friction and impacts may cause individual sparks that may cause a risk of ignition for gases of the explosion group IIC, hydrogen sulphide or ethylene oxide as well as for light metal or other impact-sensitive dusts. Therefore, spark formation caused by mechanical influences must be prevented here. The chain and load are always to be moved in such a way that sliding and/or frictional contact with other systems and components is excluded. If circumstances do not permit this, it is necessary to ensure an absence of explosive atmospheres during operation.

Impacts between special material pairings result in an increased ignition hazard. This does not apply to corrosion-resistant steel or cast iron against aluminium, magnesium or corresponding alloys. This especially applies in the presence of rust or rust film. Rust (also rust film) may form at the friction points, especially on the chain and on the load hook. The following applies for all zones: For the intended use of your product, it is to be ensured that no rust is present at the aforementioned friction points and that material combinations from the aforementioned light metals and steel (exceptions

being stainless steel) or cast iron are not used in the working area of the hoists at potential friction, impact or grinding points. It is therefore possible to exclude sparking due to mechanical influences with these material combinations.

The external housing of the service units is made of aluminium. Therefore, the installation position is to be chosen so that there is no danger from impact sparks.

Earthing Electrostatic ignition hazards can be avoided by means of safe earthing. In zones 1 and 21, it is required to earth the hoists. This must be achieved via load hooks or load eyes if the lifting equipment is connected to correspondingly earthed parts (earth leakage resistance with less than $10^6 \Omega$) This also applies for the operation of trolleys or cranes. Their tracks must be earthed on site. Generally, running wheels and rail surfaces may not be painted with lacquer coats, as this can result in unacceptably high earth leakage resistance values. Earthing of the load hook takes place via the chain. Loads must be earthed during transportation. A separate earthing is required, for example when using non-conductive sling gear.

sibility of oxidation of the metallic copper and the formation of an aqueous phase that is capable of reacting with acetylene, which could lead to a danger of explosion.

Cleaning plastic surfaces



DANGER

Danger of explosion

Electrostatic charging may occur at the plastic surfaces due to mechanical friction, potentially leading to brushing discharges that can ignite gases and air mixtures.

► Only clean surfaces with a damp cloth (cleaning cloth with water).

If your product has plastic components, their surfaces may only be cleaned with a damp cloth (cleaning cloth with water). This reduces the electrostatic charging that can result from the mechanical friction on the plastic surface.

Acetylene and copper When operating JDN products in potentially explosive areas where acetylene-containing atmospheres can occur, it must be ensured that copper-plated parts and parts made of materials with a copper content > 70% are kept dry in order to eliminate the pos-

Explosion groups and temperature classes of the most important gases and vapours (-selection-) in accordance with (DIN VDE 0165¹, Redeker², Nabert³, IEC 60079-12⁴ und IEC 60079-20⁵)

Explosion protection group	Temperature class					
	T1	T2	T3	T4	T5	T6
	Ignition temperature					
	>450°C	450-300°C	300-200°C	200-135°C	135-100°C	100-85°C
Maximum permissible surface temperature of operating facilities						
450°C	300°C	200°C	135°C	100°C	85°C	
II A	Acetone Ammonia Aniline Benzene Chlorbenzene 1,2-Dichlorbenzene Acetic acid Ethane Ethyl acetate (Ethyl bromide) Ethyl chloride (carbon monoxid) o-Cresol Methane Methyl acetate *Methyl alcohol Methyl bromide Methyl chloride Methylene chloride Naphthalene (Nitrobenzene) Phenol Propane Toluene o-Xylene	(Ethyl alcohol) (Ethyl glycol) i-Amyl acetate n-Butane n-Butyl alcohol 1-Butylene 1,2-Dichlorethane Di-i-Propyl ether Natural gas Acetic anhydride n-Propyl acetate (n-Propyl alcohol) i-Propyl alcohol Vinyl chloride	n-Amyl alcohol Petrol (fuel) Diesel Heating oil n-Hexane Jet fuels	Acetaldehyde		
II B	Hydrocyanic acid (Ethyl bromide) (carbon monoxide) (nitrobenzene) Town gas	Butadine-1,3 Dioxane-1,4 Divinyl ether (Ethyl alcohol) Ethylene (Ethyle glycol) **Ethylen oxide Isoprene (n-Propylalkohol)	Dimethyl ether **Hydrogen-sulphide	Ethyl ether Ether Schwefel ether Diethyl ether		
II C	**Hydrogen	**Acetylene				**Carbon-disulphide

(): For the substances placed in the brackets, the measured values for the classification in the explosion group or temperature class are near the limit for the next group or class. For this reason, they have been included in both.

** : extremely flammable substances (cf. additional marking "X")

* : (Methanol = methyl alcohol)

¹DIN VDE 0165: Errichten elektrischer Anlagen in explosionsgefährdeten Bereichen, 1991

²Redeker, Schön: 6. Nachtrag zu Sicherheitstechnische Kennzahlen brennbarer Gase und Dämpfe, 2. Auflage, 1990

³Nabert, Schön: Sicherheitstechnische Kennzahlen brennbarer Gase und Dämpfe, 2. Auflage, 1978

⁴IEC 60079-12: Electrical apparatus for explosive gas atmospheres, Part 12: Classification of mixtures of gases and vapours with air according to their maximum experimental safe gaps and minimum igniting currents, 1978

⁵IEC 60079-20: Electrical apparatus for explosive gas atmospheres, Part 20: Data for flammable gases and vapours, relating to the use of electric apparatus, 1996-10

Decision criteria for selecting the correct JDN products in explosion-hazardous areas

Explosion groups for gases and vapours (cf. explosion groups and temperature classes for the most important gases and vapours)	Zone		Version*			Operation**		
II A		2	A				E	
	1		A				E	
II B (X) except hydrogen sulphide, ethylene oxide (highly flammable)		2	A				E	
	1		A	FS			E	
II B		2	A	FS		D	E	
	1		A	FS		D	E	
II C / T4		2	A	FS		D	E	
	1		A	FS	FSR	D	E	
II C / T6		2	A	FS		D	E	T
	1		A	FS	FSR	D	E	T
Potentially explosive dusts								
Normal industrial dusts		22	A				E	
		21	A				E	
Light metal or impact-sensitive dusts		22	A	FS		D	E	
		21	A	FS		D	E	

* :Version features (manufacturer's responsibility):

A: The chain is made of zinc-plated steel, metal controls are conductively connected to the hoist. This is part of the standard equipment. For technological reasons, a zinc-plated version of the chain in the size 32 x 90 is not available. This is only used for the extremely slow-running chain drives of large hoists, so that the sliding velocities for potential friction points between the chain and the surroundings remain well below 1 m/s.

FS: Hoists "with increased spark protection": Copper-plated load hook and bottom flange with brass safety catch.

FSR:Running gear "with increased spark protection": Running wheels for trolleys and cranes are made of bronze.

** :Instructions for safe operation (operator's responsibility):

D: Ignition hazards are not to be expected if the hoist or crane is used as intended. Friction and impacts in the working area of the chain that do not result from the intended use of the hoist or crane and which result in sparking must be excluded, or an absence of gas in the operating area must be ensured. This means, for example, the chain, the bottom block and the load hook must be prevented from swinging against surrounding objects or that a gas-free environment must be ensured.

E: Friction, impact and grinding points involving combinations of light metal and steel or cast iron must not be present in the hoist's operating area.

T: Ambient temperature and the type of operation must be examined separately.

Temperature limits for explosion-hazardous dusts In areas that are potentially explosive due to combustible dusts, the surface temperature must not exceed two-thirds of the ignition temperature in °C of the dust/air mixture. The temperatures of surfaces on which hazardous deposits of combustible dusts can be formed must not exceed the glow temperature of the relevant dust that is reduced by 75K. Greater safety margins are required if the thickness of the dust layer exceeds 5 mm.

The corresponding surface temperatures can be derived from the lowest values for glow and ignition temperatures of dusts specified in the HVBG/BIA report 12/97 "Combustion and explosion characteristics of dusts".

Examples:

Synthetic rubber, soot-containing:
Glow temperature $220^{\circ}\text{C} - 75^{\circ}\text{C} = 145^{\circ}\text{C}$ max.
permissible surface temperature

Stearic acid:
Ignition temperature $190^{\circ}\text{C} \times 2/3 = 126^{\circ}\text{C}$ max.
permissible surface temperature

For further information: ⁶⁷⁸

3.11. CE-marking

Your product *PROFI 25 TI* is marked with CE. In the delivered design, your product meets all relevant provisions of the EC directive for which you have received a declaration of conformity.

For more information:
→ EC declaration of conformity

3.12. Spare parts

Only use **original JDN spare parts**. J.D. Neuhaus GmbH & Co. KG accepts no liability for the use of non-original components and / or modifications by unauthorised persons.

⁶Guideline 94/9/EC of the European Parliament and the Council dated 23 March 1994 on the adaptation of the laws of the Member States concerning equipment and protective systems intended for use in potentially explosive atmospheres

⁷DIN EN 1127-1: Explosive atmospheres - Explosion prevention and protection - Part 1: Basic concepts and methodology, 1997-10

⁸EN 13463-1: Non-electrical devices intended for use in explosive areas - Part 1: Basic methodology and requirements, 07/2009

4. Transport and storage

4.1. Safe transportation

NOTICE

Note the weight (approx. 550kg (1231lbs) for standard lift of 3m (10 ft), each 1m (1ft) of additional lift increases the weight by 2x 12,2kg (2x 8.2lbs)) of your product *PROFI 25 TI* during transport. Ensure that the control system is not damaged. This could lead to malfunctions.

If you want to transport your product *PROFI 25 TI* to another site of application, please observe the following points:

1. Reel the chain so that so that no loops can form and the chain cannot become twisted.
2. Depressurise the power supply and close lines so that no dirt can enter.
3. Carefully set the hoist down and do not allow it to fall.
4. Secure the chain.
5. Lay the control and supply hoses together so that they are not kinked

4.2. Storage conditions

4.2.1. Breaks in operation

1. Bring the load hook / clevis into the upper end position. Ensure that the lifting limiter is not triggered.
2. Depressurise the power supply.
3. In the event of longer breaks in operation, coat the chain and hook / eyelets with a light oil film.
4. Motor conservation: If the motor lubrication is not renewed at the specified intervals, a protective coating must be applied to the motor. For this purpose, use a non-resinous and non-sticky conserving oil with a conserving protection duration that corresponds to the length of the planned operational break.

4.2.2. Storage

1. Close off the energy supply connection pieces with a suitable cap in order to prevent dirt ingress.
2. Protect all connections from damage.
3. Store JDN product in a dry and clean location.

5. Initial operation

5.1. Unpacking

NOTICE

Note the weight (approx. 550kg (1231lbs) for standard lift of 3m (10 ft), each 1m (1ft) of additional lift increases the weight by 2x 12,2kg (2x 8.2lbs)) of your product *PROFI 25 TI* during transport. Ensure that the control system is not damaged. This could lead to malfunctions.

- ▶ Keep the accompanying documents in the place provided near the site of application.
- ▶ Lift the product carefully out of the packaging.
- ▶ Dispose of packaging in the local recycling system.

5.2. Attach the hoist

DANGER

Danger from faulty installation

A faulty installation may result in serious accidents.

- ▶ Your product *PROFI 25 TI* may only be installed by qualified personnel.

WARNING

Danger from chain fracture

Vibrations damage the chain and can lead to chain breakage.

- ▶ The supporting structure must form a rigid support.
- ▶ Furthermore, no external vibrations may be transferred to your product (e.g. from the attached load).

WARNING

Danger from inadequately sized supporting structure

When loads are taken up suddenly on slack chain, especially at high lifting speeds, impact forces result that can be several times the load weight.

- ▶ The attachment points and supporting structure for your product *PROFI 25 TI* must be able to securely absorb the forces (↔ table 1) to be expected.
- ▶ Ensure that your product can be freely aligned under load, as otherwise impermissible additional loads may occur.

Load case	Shock-force-factor	Force to support construction
Nominal load (25t)	1,1	269,8 kN
25% overload (31,3 t)	1,1	337,2 kN

Table 1: Force to support construction

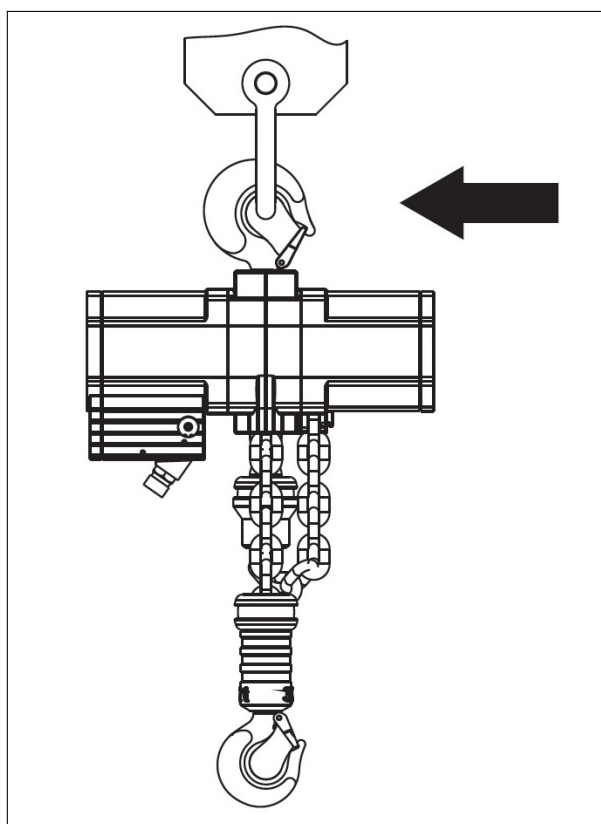

Figure 10: Securely attach the hoist

- ▶ Provide a suitable working platform.
- ▶ Hang the product on a carriage with the support hook or hang it up stationary.
- ▶ Ensure that the hook aperture safety catch closes automatically.

5.3. Connecting the power supply

The power supply for your product *PROFI 25 TI* takes place either centrally on the motor / connection block or on a service unit or filter regulator. This is connected to the compressed air hose of the power supply. The supply of the control system takes place from the control valve block.

1. Check air connection parts for dirt and clean them if necessary.
2. Spurge the compressed air hose to remove foreign bodies.
3. Connect the compressed air hose to the port. Firmly mount the hose clamp. Screw on the union nut.

5.4. Lubricating the chain

Before tests can be carried out, the chain must be lubricated.

The chain of your product *PROFI 25 TI* must be lubricated in the links in an unloaded state.

- ▶ Clean heavily soiled chains.
- ▶ Place the chain in a suitable container.
- ▶ Spray the chain with a special lubricant or vehicle engine oil.

If you want to lubricate the suspended chain, ensure that the chain links are oiled at the contact points. Move the chain back and forth to do this.

During operation in areas with a high corrosion potential, such as offshore, the chain can be largely protected against corrosion by using speciality lubricants. These types of lubricants are characterised, among other things, by a weathering resistance, water insolubility and good adhesion properties.

The re-lubrication intervals are to be set depending on the exposure. Please contact us if necessary.

5.5. Tests before commissioning

Your product *PROFI 25 TI*, including the supporting structure, must be tested by an expert prior

to the first commissioning and after significant changes before recommissioning.
Hoists built into trolleys must be tested by an expert.

The testing extends from the installation, outfitting and operational ability under normal conditions, mainly to check the completeness, suitability and effectiveness of the safety equipment, as well as to the state of the device, the lifting gear, the equipment and the load-bearing medium.

Safety devices are:

- Brake assemblies (↔ Section 5.5.3)
- Lifting limiter (↔ Section 5.5.5)
- Lowering limiter (↔ Section 5.5.6)
- Overload protection (↔ Section 5.5.4)

5.5.1. Check control device



WARNING

Danger from faulty controller

A rough-running control element or a control element that is stuck in an actuated position may indicate a faulty controller.

- ▶ Do not use the product
- ▶ Have the product repaired

1. Relieve the product *PROFI 25 TI*.
2. Briefly actuate and release all control elements of the controls one after the other. The control elements must return to their initial positions immediately. The on and off function must operate without problem.

All control elements of the controls must always be free-moving.

5.5.2. Check direction of movement

- ▶ Check that the direction of movement of the load hook corresponds to the direction indicated by the arrows on the control elements.

5.5.3. Check the braking function



WARNING

Danger from loads crashing

If the chain lags, it may be due to a faulty brake. The load may fall.

- ▶ Do not use product
- ▶ Have the product repaired

Check without load

- ▶ Alternatively switch your unloaded product *PROFI 25 TI* to lifting and lowering

If you release a control device, the chain must come to a standstill in an acceptable time after the brake has been applied. For physical reasons, however, the braking distance cannot have the value zero. The brake has a response time that is dependent on the control length. A greater control length increases this response time.

Check with nominal load

- ▶ Alternatively switch your product *PROFI 25 TI* loaded with a nominal load to lifting and lowering

If you release a control device, the chain must come to a standstill in an acceptable time after the brake has been applied. For physical reasons, however, the braking distance cannot have the value zero. The brake has a response time that is dependent on the control length. A greater control length increases this response time.

5.5.4. Check overload protection



WARNING

Danger due to overloading

If the overload protection is set too high, impermissibly high stresses may arise if a load exceeding the permissible load capacity is attached.

- ▶ Correctly set the overload protection

NOTICE

The overload protection must only be engaged briefly in order to prevent unnecessary wear and overheating of the drive.

Rules for running in hoist chains before carrying out the overload test

NOTICE

In case this information should not be observed you damage the high tensile chain in your hoist already during testing prior to initial use for which the manufacturer does not undertake any liability.

Hoist chains must be run in prior to the overload test, in order to ensure that the surface pressure at the contact points of the chain links (in the joints) can be withstood.

In preparation for overload testing, the following pre-conditions must be fulfilled:

- ▶ The joints of the chain must be thoroughly lubricated. Observe the operation instructions.
- ▶ The chain must be run in by raising and lowering it five times with approximately 50% of the nominal load capacity. This will increase the load capacity of the joints sufficiently.
- ▶ In particular, the section of the chain to be tested with the excess load must be thoroughly lubricated once again.

Only then can the overload test be performed.

The testing of the overload protection is based on the attachment of test loads.

1. Attach 125% of load capacity. If this load is lifted, the overload protection setting must be corrected.

2. Attach 110% of load capacity. This load must be lifted. A dynamic overload test of 110% of the nominal load is therefore possible.
3. The overload protection is correctly set.

5.5.5. Check lifting limiter



WARNING

Danger from chain fracture

If the buffers are damaged, inadmissibly high loads may act on the chain upon actuation of the lifting limiter. The chain may break.

- ▶ Do not use the product
- ▶ Have the product repaired (replace buffer)

1. Move the unloaded load hook until just short of the upper end position.
2. Stop immediately before reaching the end position and then carefully (by repeatedly pressing the control element) move to the end position.
3. The movement of the chain must be stopped due to deformation of the buffer. Due to the overload protection, the lifting movement is additionally limited by shutting off the motor.
4. Following successful testing, the buffer must be unloaded.

5.5.6. Check lowering limiter



WARNING

Danger from chain fracture

If the buffers are damaged, inadmissibly high loads may act on the chain upon actuation of the lowering limiter. The chain may break.

- ▶ Do not use the product
- ▶ Have the product repaired (replace buffer)

1. Move the unloaded load hook until just short of the lower end position.
2. Stop immediately before reaching the end position and then carefully (by repeatedly pressing the control element) move to the end position.
3. The movement of the chain must be stopped due to deformation of the buffer. The engine will stall in the process.
4. Following successful testing, the buffer must be unloaded.

6. Operation

6.1. Rules for safe operation

As an operator, you are responsible for your own safety and the safety of your colleagues in the working area of the product *PROFI 25 TI*.

- The product *PROFI 25 TI* may only be operated by persons authorised by the contractor.
- Before using the product for the first time, familiarise yourself with all permissible operating conditions. To this end, please read these operating instructions carefully and follow all of the activities described for this product, step by step.
- Report any malfunction to your safety officer immediately so that the fault can be rectified at once.
- Follow the regulations of the accident protection organisation, in Germany for example the accident prevention regulations of the professional associations.
- Note the points for *Proper use* und *Improper use*

For the safety of persons and property when dealing with your product *PROFI 25 TI*, it is crucial to observe the following points:

- Never stress the chain to where it bends.
- Do not join or repair the chain.
- Do not work with a chain that is drawn tight, bent or extended.
- Do not work with a chain that is damaged, worn or rusty.
- Check a blocked chain for damage.
- Organise twisted chains.
- Permissible operating temperature for chain and hook: -40°C (-40°F) to +150°C (302°F).
- Never allow loads to fall onto the chain.
- Never touch a running chain.
- Never use the chain to sling loads.
- Do not assume the load at maximum speed if the chain is hanging slack.
- Repair the product if the braking distance is too long.
- Only use an original JDN chain container.

- Do not exceed the permissible fill capacity of the chain container.
- When operating the chain container, avoid dangers from an empty chain (falling, catching, striking).
- Never touch metallic hand controls that are colder than 0°C (32°F) or hotter than 43°C (109°F) without suitable protective gloves.
- Repair the product if the operating controls are difficult to move.
- Never lock the control devices of the control system equipment.
- Only operate your product *PROFI 25 TI* with original JDN controls.
- Observe the corresponding instructions when slinging loads.
- Only use suitable and approved slinging aids.
- Before lifting loads, ensure that the maximum permissible load is not exceeded! Slinging aids must be added to the load.
- Before slinging, align the load exactly vertically under the product. Chain must hang vertically before lifting.
- Always only lift one load, never several loads simultaneously.
- When lifting and setting down, ensure a stable position of the load to avoid accidents from the load tipping or falling down.
- Never drive against stuck loads.
- Only use suitable and approved slinging aids. Do not jam the hook/clevis at the attachment point.
- In the event of a power failure, secure the load and the area around the load until the power supply is restored.
- Do not kink or squeeze the control hoses.
- Shut off the power supply before disconnecting the hoses.
- Ensure the correct system pressure.
- Move a bottom block lying on the ground back into a hanging position in a controlled manner (even bearing chain strands)
- If a load with several products is lifted, avoid overloading due to an incorrect load distribution.

- Have detached screw connections from repair attached.
- When lifting loads in non-visible areas, special safety precautions must be taken.
- Uncontrolled external force impacts (such as from hydraulic cylinder, falling loads) are not allowed.
- Never allow persons to stay under a suspended load.
- Never try to correct a fault with a suspended load.
- Ensure that there is no threat to the operator at the workplace due to slings or the load.
- Choose a safe site of operation.
- Do not make any changes to the product.
- Only use original JDN spare parts. J.D. Neuhaus GmbH & Co. KG accepts no liability for the use of non-original components and / or modifications by unauthorised persons.

Contractor's operating instructions For particularly difficult cases of application with your product, the contractor must create operating instructions in an intelligible form in the operator's language while taking this user manual into consideration.

These instructions shall regulate measures for safe operation according to the operational conditions.

In addition, all information must be strictly observed that is listed in the sections of *Proper use*, *Improper use* und *Operating conditions* aufgeführt sind.

6.2. Attaching the load



WARNING

Danger to life from being struck

Improper attaching the load can lead to the load crashing down.

- ▶ Only use slinging chains or attachment chains (sling gear) suitable for the load.
- ▶ Loads may not be slung by looping with the lift chain / load chain.

In Germany, the professional association rule "Operation of load lifting equipment in hoist operation" is to be followed (BGR 258).

In other countries, corresponding national regulations are to be observed.

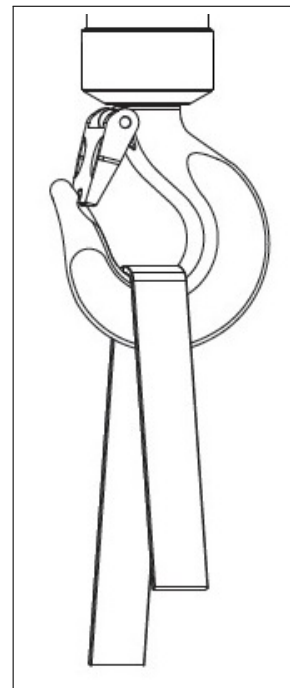

Figure 11: Safely attaching loads

- ▶ Connect the sling gear at the lowest point of the hook. Never load the hook nose (↔ Figure 11).
- ▶ Ensure that the hook aperture safety catch is closed.

6.3. Lifting the load

NOTICE

It must be possible to freely align your product *PROFI 25 TI* under load. Otherwise, impermissible additional forces occur, which can damage the components of the hoist.

- ▶ First lift the load hook /lug or load eye in order to pull the slacking chain taut. Briefly interrupt the lifting process when tightening the chain. The hoist can be aligned and the material is protected.
- ▶ Then lift the load.

For loads whose weight is above the set limit of the overload protection, the overload protection will stop the lifting process.

6.4. Lowering the load

DANGER

Danger to life from being struck

People can be struck and killed from lowering loads.

- ▶ Make sure that no one is below the load or in the hazard area of the load.

NOTICE

Danger from overloading! Ensure that for all applications of your product *PROFI 25 TI* the load hook / clevis can be lowered all the way to the ground to avoid a load being driven into the lower limit position without reaching the ground.

- ▶ Lower the load and carefully set it down.

6.5. Releasing the load (detaching)

- ▶ Lower the load hook / clevis so far that the load no longer is exerting any force on the load-bearing medium (e.g. by securely setting it down), detach the load
- ▶ Move the load hook / clevis out of the traffic area to avoid dangers.

6.6. Interrupting work

If you want to interrupt work with your product:

- ▶ Set down and release the load.
- ▶ Move the load hook / clevis out of the traffic area to avoid dangers.

7. Decommissioning

7.1. Disassembly



CAUTION

Danger from faulty disassembly

Improper disassembly can lead to injuries.

► Your product *PROFI 25 TI* may only be dismantled by qualified personnel.

1. Depressurise the power supply.
2. Provide a suitable working platform.
3. Remove the hose.
4. Protect the connection pieces from the ingress of dirt.
5. Release the control hoses. Do not kink the control hoses!
6. Mark the connections.
7. Loosen the strain relief or hose support and remove the control device.
8. Carefully hang up your product *PROFI 25 TI* and transport away



7.2. Disposal

Your product *PROFI 25 TI* contains a series of materials that you may have to dispose of or have recycled after the end of their useful lives according to statutory provisions.

Please note the following list of materials used:

- Ferrous materials: Steel, spheroidal graphite iron
- Non-ferrous metals: Bronze, aluminium, brass
- Plastics: Polyurethane, polyoxymethylene, polyvinyl chloride, glass-fibre reinforced polyamide, rubber, polypropylene, phenolic resin, epoxy resin, thermosetting moulding material (asbestos-free brake pads), synthetic rubber

8. Maintenance

 CAUTION
<p>Danger of burns Burns can occur when touching metallic surfaces that are hotter than 43°C (109°F). ▶ Wear protective gloves.</p>
 CAUTION
<p>Danger of frostbite Frostbite can occur when touching metallic surfaces that are colder than 0°C (32°F). ▶ Wear protective gloves.</p>
 CAUTION
<p>Danger from improper repair Improper repair can lead to errors on the product and thus to hazardous situations. ▶ Maintenance work on your product may only be performed by trained and qualified personnel!</p>

Your product is very sturdy and requires very little maintenance. Compliance with maintenance and inspection intervals is of great importance in order that your product *PROFI 25 TI* operates safely and reliably over a period of many years.

8.1. Inspection and repairs

Your product *PROFI 25 TI* was classified into groups and dimensioned according to the type of operation (driving mechanism classification according to ISO/FEM). The average daily operating time and the load spectrum determine the classification. This is assuming that the lifting and lowering paths are approximately the same.

For devices used mainly in vertical operation (from 75% of on-time), the theoretical operating time is reduced due to the higher lowering speed in the range from 50% to 100% of the nominal load.

Therefore, the determined portion of the theoretical operating time must be multiplied by a factor of f_v .

The factor f_v has a value of 1 at 50% of the nom-

inal load, increasing linearly to 1.5 at 100% of the nominal load (nominal load percentage P).

$$f_v = 1 + 0,5 \cdot \frac{P-50}{50} \text{ for } P > 50\%$$

In order to achieve safe operating periods, the company must check that the theoretical operating time has been achieved during each inspection, by the person responsible.

This must be documented in the inspection log at least once annually. The inspection log is only supplied in the Federal Republic of Germany.

When the theoretical operating time has been reached, a general overhaul must be performed. Detailed explanations for the determination of the actual operating time and its documentation can be found in the national safety regulations. Alternatively, the calculation model in these operation instructions can be used. The general overhaul must be initiated by the operator and must be documented in the inspection log. Information on general overhaul can be requested from the manufacturer.

Only if the group classification corresponds to the actual mode of operation of the product does a safe operating period conform to the theoretical operating time. Deviations of the actual mode of operation from the underlying mode of operation extend or shorten the safe operating period. For all inspection work that is not a part of the daily inspection, suitable access to the product must be ensured. The hoist must be disconnected from the energy supply during assembly work.

Following each repair, the product must be checked for operational readiness.

8.2. Model for determining the actual use

The decisive factors for the type of operation are the load spectrums with different cubic averages k . The load spectrum indicates to what extent a driving mechanism, or part of one, is subjected to its maximum stress or whether it is only subjected to lower stresses. The cubic mean value (factor of the load spectrum) is calculated using the following formula:

$$k = \sqrt[3]{(\beta_1 + \gamma)^3 \cdot t_1 + (\beta_2 + \gamma)^3 \cdot t_2 + \dots + \gamma^3 \cdot t_\Delta}$$

Darin bedeuten:

$$\beta = \frac{\text{Payload or ultimate load}}{\text{Load capacity}}$$

$$\gamma = \frac{\text{Dead load}}{\text{Load capacity}}$$

$$k = \frac{\text{Operating time with payload or partial load and dead load}}{\text{Total operating time}}$$

$$t_\Delta = \frac{\text{Operating time with dead load}}{\text{Total operating time}}$$

The FEM 9.511 rule differentiates between four load spectrums, which are identified by the definitions and by the ranges of the cubic averages k . This classification complies with ISO 4301/1.

The formula given for the cubic average k does not take the weight of the harness into account. This is permissible if the ratio

$$\frac{\text{Weight of the harness}}{\text{Load capacity}} \leq 0,05$$

To determine the mode of operation for calculating the partial operating times (actual operating time), the following load spectrum diagrams can also be used.

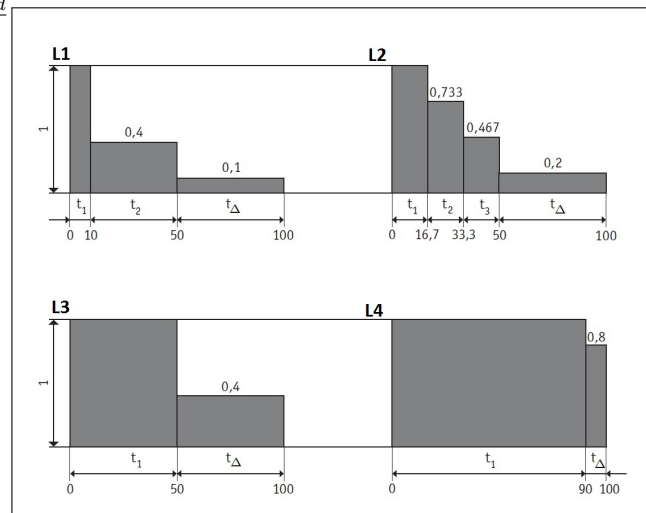

Figure 12: Diagram of the load spectrums

Load spectrum	Definition	Cubic average	Collective load factor
L1 (light)	Driving mechanisms or parts thereof, which are only subject to the maximum stress in exceptional circumstances and are only subject to very low stresses continuously.	$k \leq 0,50$	$k_m = k^3 = 0,125$
L2 (medium)	Driving mechanisms or parts thereof, which are subject to the maximum stress fairly often and are only subject to low stresses continuously.	$0,50 < k \leq 0,63$	$k_m = k^3 = 0,25$
L3 (heavy)	Driving mechanisms or parts thereof, which are often subject to the maximum stress and are continuously subject to average stresses.	$0,63 < k \leq 0,80$	$k_m = k^3 = 0,5$
L4 (very heavy)	Driving mechanisms or parts thereof, which are regularly subject to the maximum stress of adjacent stresses.	$0,80 < k \leq 1,00$	$k_m = k^3 = 1$

8.3. Maintenance and inspection intervals

The specified inspection intervals are valid for use in accordance with the classification. The service life is approx. 10 years if the device is used in accordance with its classification.

If your product is used more intensively, the intervals are to be shortened accordingly. All operating hours are translated into full load hours. The theoretical operating time and the interval hours are indicated in full load hours.

Maintenance and inspection measures	Interval	Section / comment
Check control device	Daily	↔ 8.7, Page 50
Check direction of movement	Daily	↔ 8.8, Page 50
Check brake function without load	Daily	↔ 8.9, Page 50
Visually inspect the buffer of lifting and lowering limiters	Daily	↔ 8.10, Page 51
Visually inspect the chain	Weekly	↔ 8.14, Page 53
Check chain	Every 3 months	↔ 8.14, Page 53
Lubricating the chain	As required	↔ 8.6.2, Page 47
Check lifting limiter	Annually	↔ 8.11, Page 51
Check lowering limiter	Annually	↔ 8.12, Page 52
Check brake function with nominal load	Annually	↔ 8.9, Page 50
Check hook, shackle, eyelets	Annually	↔ 8.17, Page 55
Check silencer	Annually	↔ 8.18, Page 56
Check overload protection	Annually	↔ 8.13, Page 52
Check all the bolted and pin connections	Annually	For tightening torques, ↔ see spare parts list.
Check the connections and hose lines for damage	Annually	Replace damaged parts if necessary

Check control valve for sealing efficiency	Annually	Replace damaged parts if necessary
Check lifting motor	every 200 full load hours / every 5 years	→ 8.19, Page 56
Replace chain (in corrosive environment)	at least every 5 years	
Check chain sprocket	Whenever the chain is replaced	↔ 8.15, Page 54
Check chain guide and hook mount	Whenever the chain is replaced	↔ 8.16, Page 54
Lubricate lifting motor	When required, at least every 5 years	↔ 8.6.3, Page 48
Check gearbox and perform lubricant change	Every 5 years	↔ Spare parts list
Check and lubricate the rotor/pinion shaft connection	Every 5 years	↔ Spare parts list
Check the chain sprocket bearings and lubricate if necessary	Every 5 years	↔ Spare parts list

8.4. Spare parts

Only use **original JDN spare parts**. J.D. Neuhaus GmbH & Co. KG accepts no liability for the use of non-original components and / or modifications by unauthorised persons.

8.5. Cleaning and care

DANGER

Danger of explosion

Electrostatic charging may occur at the plastic surfaces due to mechanical friction, potentially leading to brushing discharges that can ignite gases and air mixtures.

- ▶ Only clean the surfaces with a damp cloth (cleaning cloth with water).

If your product *PROFI 25 TI* is often used at different locations, particularly in dirty and damp environments,

- ▶ clean coarse dirt from your product,
- ▶ protect your product from corrosion.

8.6. Lubricate and grease

8.6.1. Operating materials

CAUTION

Danger of skin irritation

Oils and greases may cause skin irritation.
▶ Wear protective gloves

NOTICE

Do not mix synthetic oils or greases with mineral oils or greases, as the properties may deteriorate. Also never mix different types of lubricating grease within the synthetic or mineral lubricant groups. When operating with oilers, synthetic lubricants may never be used. Alcohols are not permitted as de-icing agents.

The following operating materials and lubricants are intended for normal environmental influences. In the event of environmental influences that promote wear, please contact J.D. Neuhaus to obtain appropriate information.

Application area	Operating material
Motor lubrication	JDN high performance grease, item no. 11904 (250ml)
Engine lubrication for operation with oiler	Air lubricator "D", kinematic viscosity about $30 \frac{mm^2}{s}$ (cSt) bei 40°C, possibly with anti-icing agent
Chain lubrication	Chain oil or vehicle motor oil, kinematic viscosity about $150 \frac{mm^2}{s}$ (cSt) at 40°C, or special lubricant from J.D. Neuhaus. In areas with extreme corrosion potential, such as offshore, a lubricant with a particularly powerful corrosion protection is to be used.
Engine corrosion protection (not applicable if using the JDN high performance grease)	Non-gumming preservative oil with corresponding effective duration
Engine cleaning (not applicable if using the JDN high performance grease)	Pure petroleum
Lubrication for bearings and gearbox (also for open gears)	Lithium-saponified grease, worked penetration 265-295 (0,1mm), base oil viscosity: $190 \frac{mm^2}{s}$ (cSt) bei 40°C, dropping point: 180°C, Application temperatures: -20°C bis + 120°C, Designation according to DIN 51825: KP2K-20, active ingredients: EP additives (to reduce wear) and ageing protection; water-resistant and anti-corrosive

8.6.2. Lubricating the chain

Before tests can be carried out, the chain must be lubricated.

The chain of your product *PROFI 25 TI* must be lubricated in the links in an unloaded state.

- ▶ Clean heavily soiled chains.
- ▶ Place the chain in a suitable container.
- ▶ Spray the chain with a special lubricant or vehicle engine oil.

If you want to lubricate the suspended chain, ensure that the chain links are oiled at the contact points. Move the chain back and forth to do this.

During operation in areas with a high corrosion potential, such as offshore, the chain can be largely protected against corrosion by using speciality lubricants. These types of lubricants are characterised, among other things, by a weathering resistance, water insolubility and good adhesion properties.

The re-lubrication intervals are to be set depending on the exposure. Please contact us if necessary.

8.6.3. Re-lubricate the lifting motor

CAUTION

Danger of injury from pre-tensioned springs

Pre-tensioned springs are released when disassembling the engine covers.

► Carefully loosen and remove the engine cover!

NOTICE

The grease filling in the rotor chambers is sufficient for approximately 250 hours under normal operating conditions. The rotor chambers only empty to approximately 75%. In this condition, refilling must be performed.

NOTICE

See the spare parts list for tightening torques

In order to re-lubricate the motor, it must be removed (Abbildung (↔) Figure 13, the lifting motor can be removed from the hoist to simplify matters):

1. Engine disassembly:

- a) Relieve the product and disconnect from the power supply.
- b) Unscrew the nameplate **(1)**.
- c) Remove the motor cover bolts **(2)** and detach the engine cover **(3)** (when the cover bolts are loosened, the tension in the brake springs **(4)** is fully released).
- d) Remove the brake springs.
- e) Remove the brake piston **(5)** from the internal cylinder integrated in the engine housing. If present, bore holes can be used to facilitate assembly.
- f) Pull out the rotor **(6)** together with vanes **(7)** and starting aids **(8)**.

2. Renewing motor lubrication:

The retaining rings **(9)** and Vyon washers **(10)** must be removed in order to refill the lubrication chambers of the rotor. Then fill the lubricant chambers with high-performance lubricant (JDN item. no 11904) without forming cavities! Use new Vyon washers to close off

the lubricant chambers and secure these using retaining rings.

3. Engine assembly with additional basic lubrication of the engine:

- a) Provide the braking surface and rotor bearing (needle bush) of the cover with the brake pad with a thin layer of high-performance lubricant.
- b) Coat the internal cylinder of the motor housing lightly with high-performance grease
- c) Coat the entire rotor lightly with high-performance grease and insert into the front rotor bearing with the clutch side first.
- d) Coat the vanes lightly with high-performance grease and insert into the rotor slots with the starting aids.
- e) Coat the entire braking piston surface, including the brake piston seal, lightly with high-performance lubricant and push the brake piston into the internal cylinder with the braking surface first. Note the position of the eccentric bore.
- f) Insert the brake springs into the bores of the brake piston.
- g) Loosen adjustment bolts **(14)** and lock nuts **(15)**. Screw back adjusting bolts sufficiently.
- h) Apply high-performance grease lightly to rotor bearing (needle bush) in the motor cover and install motor cover. Ensure correct seating of the brake springs and the locating pins to the motor housing and to the brake piston. Do not tighten the four adjusting bolts after bolting the motor cover in place, only screw them in loosely by hand to the stop in the cover. Screw back the lock nuts sufficiently beforehand.
- i) Then screw back the adjusting bolts 45° from the stop, hold and lock with the nuts. For lifting heights of 10 metres (33 feet) and more, a setting of up to 60° may be required. For operation in areas with ambient temperatures exceeding 30°C (86°F), the adjustment must be

carried out with the device warmed up accordingly.

j) Tighten the nameplate (1) .

4. Check the braking action under nominal load (run in the brake by performing several hoisting cycles, then assess) prior to initial operation. Check the motor power. In the event of low motor power, regulate the adjusting bolts again.

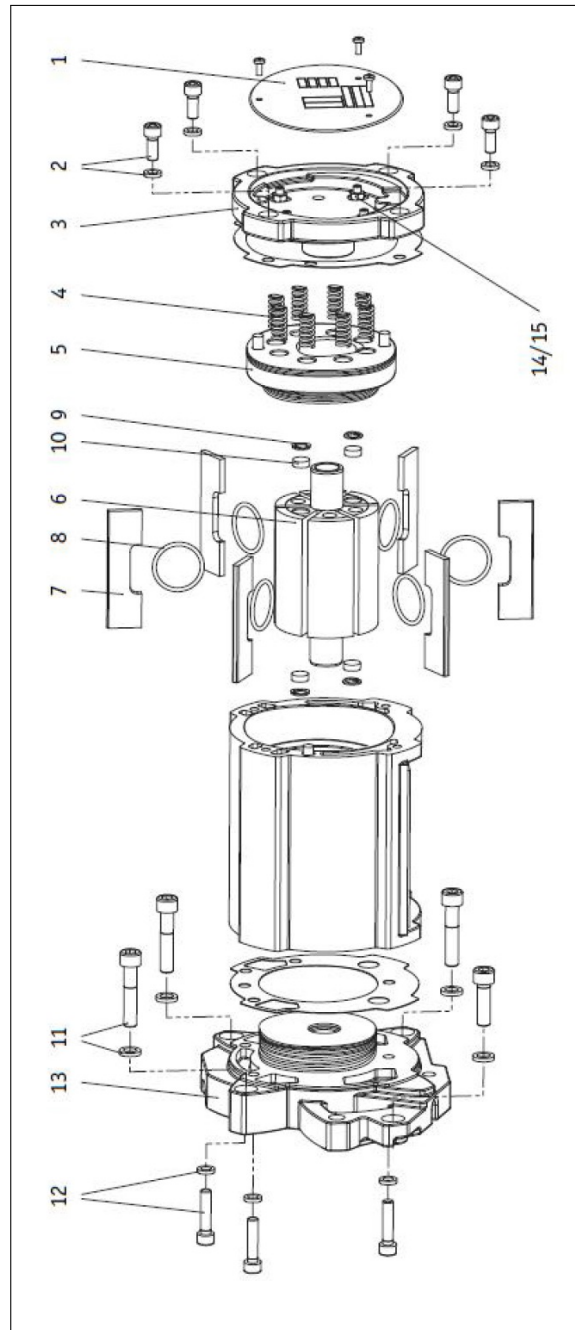

Figure 13: Lifting motor

8.7. Check control device

WARNING

Danger from faulty controller

A rough-running control element or a control element that is stuck in an actuated position may indicate a faulty controller.

- ▶ Do not use the product
- ▶ Have the product repaired

1. Relieve the product *PROFI 25 TI*.
2. Briefly actuate and release all control elements of the controls one after the other. The control elements must return to their initial positions immediately. The on and off function must operate without problem.

All control elements of the controls must always be free-moving.

8.8. Check direction of movement

- ▶ Check that the direction of movement of the load hook corresponds to the direction indicated by the arrows on the control elements.

8.9. Check the braking function

WARNING

Danger from loads crashing

If the chain lags, it may be due to a faulty brake. The load may fall.

- ▶ Do not use the product
- ▶ Have the product repaired

Check without load

- ▶ Alternately switch your unloaded product *PROFI 25 TI* between lifting and lowering

If you release a control device, the chain must come to a standstill in an acceptable time after the brake has been applied. For physical reasons, however, the braking distance cannot have the value zero. The brake has a response time that is dependent on the control length. A greater control length increases this response time.

Check with nominal load

- ▶ Alternately switch your unloaded product *PROFI 25 TI* between lifting and lowering

If you release a control device, the chain must come to a standstill in an acceptable time after the brake has been applied. For physical reasons, however, the braking distance cannot have the value zero. The brake has a response time that is dependent on the control length. A greater control length increases this response time.

8.10. Check the buffer



WARNING

Danger from chain fracture

A damaged or non-existent buffer can lead to a fracture of the chain if the upper or lower hook end position is met.

- ▶ Have the product repaired (replace buffer)

The buffer of the lifting limiter (optional) and lowering limiter must be visually inspected daily. If the buffers have cracks, permanent deformations or other damage, they must be replaced.

8.11. Check lifting limiter



WARNING

Danger from chain fracture

If the buffers are damaged, inadmissibly high loads may act on the chain upon actuation of the lifting limiter. The chain may break.

- ▶ Do not use the product
- ▶ Have the product repaired (replace buffer)

1. Move the unloaded load hook until just short of the upper end position.
2. Stop immediately before reaching the end position and then carefully (by repeatedly pressing the control element) move to the end position.
3. The movement of the chain must be stopped due to deformation of the buffer. Due to the overload protection, the lifting movement is additionally limited by shutting off the motor.
4. Following successful testing, the buffer must be unloaded.

8.12. Check lowering limiter

WARNING

Danger from chain fracture

If the buffers are damaged, inadmissibly high loads may act on the chain upon actuation of the lowering limiter. The chain may break.

- ▶ Do not use the product
- ▶ Have the product repaired (replace buffer)

1. Move the unloaded load hook until just short of the lower end position.
2. Stop immediately before reaching the end position and then carefully (by repeatedly pressing the control element) move to the end position.
3. The movement of the chain must be stopped due to deformation of the buffer. The engine will stall in the process.
4. Following successful testing, the buffer must be unloaded.

8.13. Check overload protection

WARNING

Danger due to overloading

If the overload protection is set too high, impermissibly high stresses may arise if a load exceeding the permissible load capacity is attached.

- ▶ Correctly set the overload protection

NOTICE

The adjustment is usually made at room temperature (approximately 20°C (68°F)). In the event of very high or very low operating temperatures, the adjustment is to be corrected in relation to the temperature.

The testing of the overload protection is based on the attachment of test loads.

1. Attach 125% of load capacity. If this load is lifted, the overload protection setting must be corrected.
2. Attach 110% of load capacity. This load must be lifted. A dynamic overload test of 110% of the nominal load is therefore possible.

The overload protection is correctly set.

Adjusting overload protection The adjustment method described here is based on the attachment of test loads (↔ Figure 14). The overload protection is located in the control valve.

1. Attach overload of 125% of the load capacity.
2. If this overload is lifted, the adjusting bolt (1) must be adjusted clockwise until it is no longer possible to lift the overload. If the overload is not lifted, the adjusting bolt must be adjusted anticlockwise until it is possible to lift the overload. Then it must be adjusted back until it is no longer possible for it to lift the overload.
3. After the adjustment process, it must be possible to lift 110% of the nominal load. A dynamic overload test of 110% of the nominal load is therefore possible.

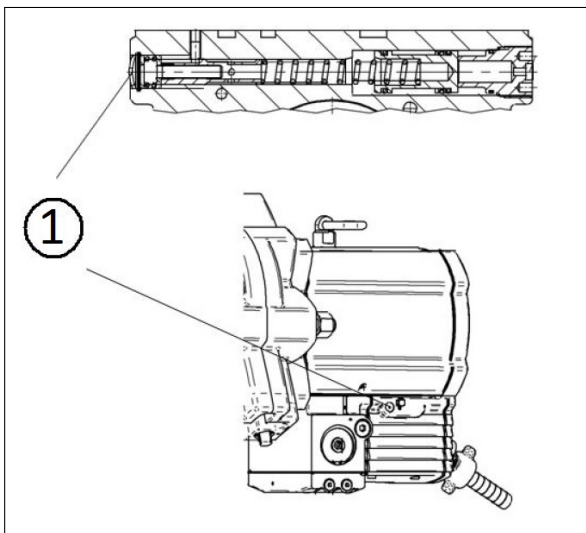

Figure 14: Adjusting overload protection

8.14. Check chain

WARNING

Danger from chain fracture

If the chain of your product *PROFI 25 TI* has one of the features listed below, the chain may break upon further use.

- ▶ Do not use the product
- ▶ Replace the chain

- Corrosion pitting
- Bent or damaged chain links
- Chain drawn tight
- Wear over 11 pitches (dimension A)
- Single pitch wear (dimension B)
- Diameter reduction of a chain link (dimension C)
- Elongation of a chain link (dimension D)

Check the entire length of the chain. When checking the replacement limit, future wear up until the next inspection date must be taken into account. If the chain dimension values are outside the limit values specified in the table when checked, the chain has reached its replacement limit and must be replaced by a new one.

The chain sprockets must also be replaced together with the chain, as otherwise the new chain will be subjected to increased wear. Each chain replacement must be documented in the inspection log.

Please observe the information contained in

↔ DIN 685, Part 5

↔ ISO 7592

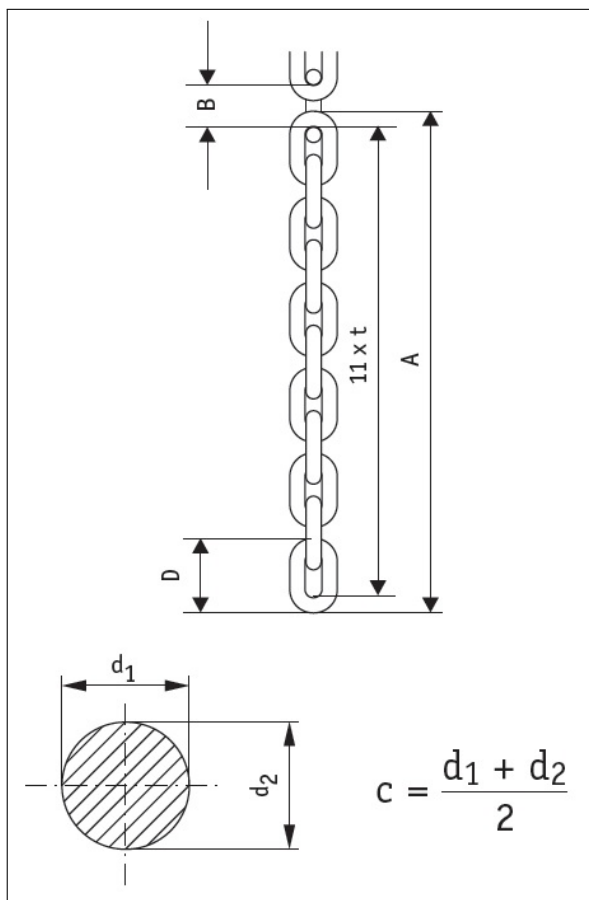

Figure 15: Check chain

Dimension A max.	787,9mm
11 x t inside max.	743,0mm
Dimension B max.	69,5mm
Dimension C min.	21,2mm
Dimension D max.	116,4mm

8.15. Check chain sprocket

NOTICE

If the wear dimensions of a chain sprocket are outside of the limit dimensions indicated below, then the chain sprocket is to be replaced.

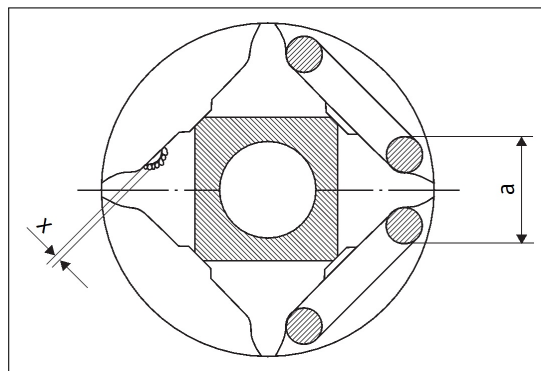

Figure 16: Four-tooth chain sprocket

z	a_{min}	x_{max}
4	60,0 mm	0,45 mm
5	59,6 mm	0,45 mm

z: Number of teeth of the chain sprocket

a,x: Limit dimensions after maximum permitted wear

8.16. Check the chain guide and hook mount

Check the chain guides for wear and when the wear dimension of 2,3mm is reached with regard to chain guide diameters or hook mounts in the centre section of the device: Replace the housing.

The wear dimension must be measured at the points on the guide surfaces which have been worn down by the chain.

8.17. Check the hook, shackle and eyelets

Check load and support hook If the dimension x , y or h of the load hook (support hook) is outside of the limit value, the hook must be replaced.

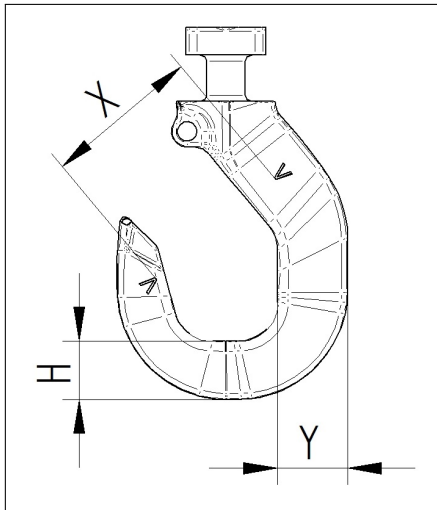

Figure 17: Check dimensions of load hook (support hook)

Dimension	Dimension	Dimension
x_{max}	y_{min}	h_{min}
148,2 mm	113,0 mm	81,0 mm

Checking axial clearance If the axial clearance between the installed hook/clevis and bottom block increases rapidly, it must be assumed that the hardened surfaces of the mount are worn. The worn parts of the mount must then be replaced immediately. The actual dimensions of the mount must be measured and recorded before initial operation. Following repair or overhaul of the mount, the actual dimensions must be determined again. Rapid wear can be detected quickly due to the rapid increase in the dimension z . The point of departure is the actual measured dimension in new condition.

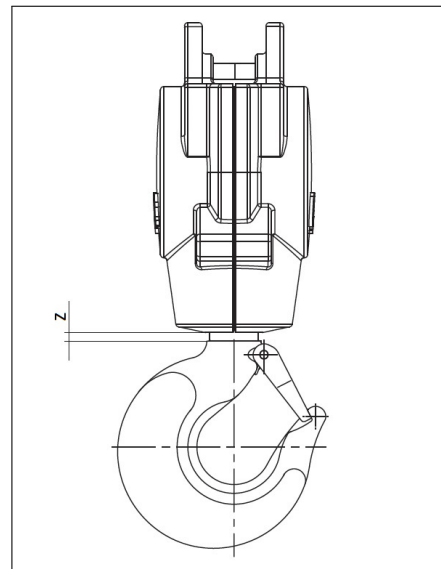

Figure 18: Permissible maximum dimension of the axial clearance z

Date	Axial clearance z
Actual dimensions for new device	

8.18. Check silencer

CAUTION

Danger from noise

By removing the silencer, the noise pressure level of the product increases.

► Always wear appropriate protection equipment

In addition to the scheduled inspection intervals, the silencer should be inspected and its flow resistance assessed whenever the hoist fails to reach the specified lifting speed.

The test is performed by comparing the lifting speeds under nominal load, with and without the silencer. The speed must be at least 80% of the lifting speed without a silencer element.

In the event of lower values, the silencer elements must be cleaned or replaced.

8.19. Check lifting motor

CAUTION

Danger of injury from pre-tensioned springs

Pre-tensioned springs are released when disassembling the engine covers.

► Carefully loosen and remove the engine cover!

NOTICE

See the spare parts list for tightening torques

In order to check the lifting motor, it must be removed ((↔) Figure 13, the lifting motor can be removed from the hoist to simplify matters):

1. Engine disassembly:

- a) Relieve the product and disconnect from the power supply.
- b) Unscrew the nameplate **(1)**.
- c) Remove the motor cover bolts **(2)** and detach the engine cover **(3)** (when the cover bolts are loosened, the tension in the brake springs **(4)** is fully released).
- d) Remove the brake springs.
- e) Remove the brake piston **(5)** from the internal cylinder integrated in the engine housing.
- f) Pull out the rotor **(6)** together with the vanes **(7)** and starting aids **(8)** (if present, two bore holes can be used to facilitate assembly).

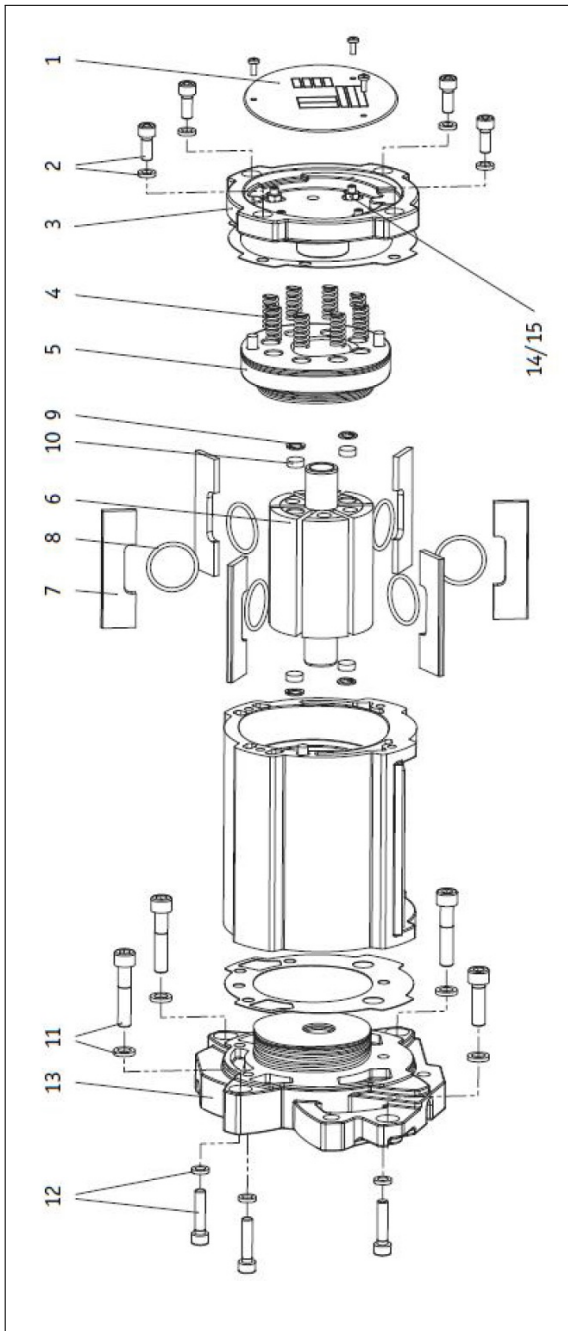

Figure 19: Lifting motor

2. Checking vane wear: When the vanes (7) are worn, the engine power is reduced. Replace the vanes (7) and starting aids (8) together.

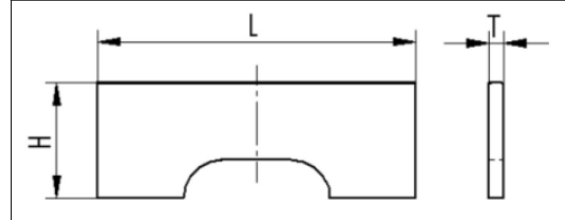

Figure 20: Vane

Vane dimensions after maximum permissible wear (measured at the thinnest point):

L	H	T
109,1 mm	35,0 mm	5,4 mm

3. Check the braking surfaces of the brake piston (5) and the cover with brake lining (13) for wear and damage: If the braking surfaces are damaged or worn, the brake piston (5) or the middle part half with the brake lining must be replaced:
 - a) The circular wear pattern in the brake surfaces must not be deeper than 0.02mm:
The extremely low-wear braking material will not reach the wear limit of 0.02mm within the design-dependent service life of the hoist, under intended use. Should the wear limit be reached prematurely, the actual compressed air pressure must be checked with the device switched on (the brake drags in the event of insufficient pressure).
4. Engine assembly with additional basic lubrication of the engine:
 - a) Provide the braking surface and rotor bearing (needle bush) of the cover with the brake pad with a thin layer of high-performance lubricant.
 - b) Coat the internal cylinder of the motor housing lightly with high-performance grease
 - c) Coat the entire rotor lightly with high-performance grease and insert into the front rotor bearing with the clutch side first.

- d) Coat the vanes lightly with high-performance grease and insert into the rotor slots with the starting aids.
 - e) Coat the entire braking piston surface, including the brake piston seal, lightly with high-performance lubricant and push the brake piston into the internal cylinder with the braking surface first. Note the position of the eccentric bore.
 - f) Insert the brake springs into the bores of the brake piston.
 - g) Loosen adjustment bolts **(14)** and lock nuts **(15)**. Screw back adjusting bolts sufficiently.
 - h) Apply high-performance grease lightly to rotor bearing (needle bush) in the motor cover and install motor cover. Ensure correct seating of the brake springs and the locating pins to the motor housing and to the brake piston.
 - i) Do not tighten the four adjusting bolts after bolting the motor cover in place, only screw them in loosely by hand to the stop in the cover. Screw back the lock nuts sufficiently beforehand.
 - j) Then screw back the adjusting bolts 45° from the stop, hold and lock with the nuts. For lifting heights of 10 metres (33 feet) and more, a setting of up to 60° may be required. For operation in areas with ambient temperatures exceeding 30°C (86°F), the adjustment must be carried out with the device warmed up accordingly.
 - k) Tighten the nameplate **(1)**.
5. Check the braking action under nominal load (run in the brake by performing several hoisting cycles, then assess) prior to initial operation. Check the motor power. In the event of low motor power, regulate the adjusting bolts again.

8.20. Replace chain



WARNING

Danger from chain fracture

The chain is subjected to impermissible stresses if the chain is twisted.

► Do not twist the chain!

NOTICE

JDN chains are matched in close tolerances to the sprocket. In order to ensure an optimum function of the chain and in order to prevent dangers, only genuine JDN chains may be installed.

NOTICE

If the chain end link of the load chain is positioned incorrectly, it must be removed. The following chain link will then be positioned correctly.

The spare parts list contains information about torques and other representations of the individual components.

1. Loosen the chain from the dead end chain mount **(9)**.
2. Remove components on the idle **(1)-(3)**:
 - a) Loosen the clamp.
 - b) Remove the components **(1)-(3)** from the chain.
3. Loosen the chain from the load chain attachment **(5)**.
4. Attach the new chain to the end link of the load section of the old chain after aligning the welds and the first chain link by means of an open chain link. The welds of the old and new chain must have the same orientation.
5. Switch *PROFI 25 TI* to Lifting and run the new chain through the bottom block and drive chain sprocket. After it exits, take the old chain and open chain link from the new chain.
6. Align the chain and fasten the chain end link **(5)** by means of the chain end link bolt (position of the weld must align with that of the following links). If necessary, the last chain link must also be separated.

7. Mount the components on the idle chain:
 - a) Slide the buffer washers **(3)** (edge encloses buffer) and buffer **(2)** onto the chain.
 - b) Fasten clamping piece **(1)** to the 12th chain link and secure with screws.
 - c) Fasten the chain end link in the dead end chain mount.
8. The replacement of the chain for a new chain is to be entered in the test book.

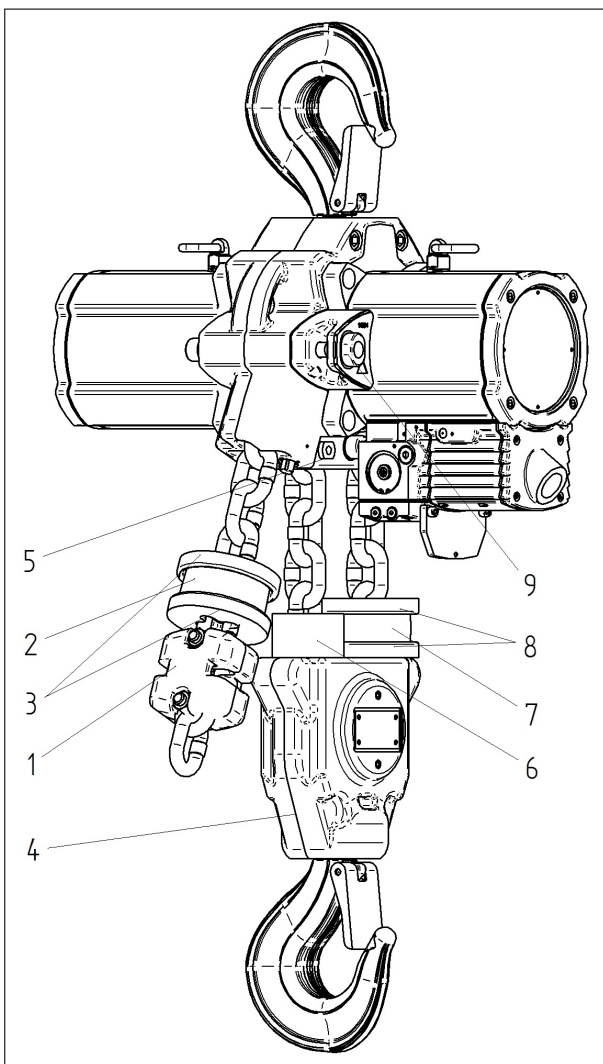

Figure 21: Replace chain

9. Faults, causes and remedies

LIFTING NOT POSSIBLE OR ONLY POSSIBLE VERY SLOWLY

Possible cause	Remedy
Insufficient inlet pressure	Increase inlet pressure to the required value.
Input volume too low	Increase input volume to the required value.
Overload protection has caused deactivation	Lower hook briefly, limit load to permissible load capacity, then lift again. If loads within the load capacity range are not lifted, the overload protection must be adjusted. Set the pressure correctly. Pressures that are too high can cause deactivations within the load capacity range.
Hand control is faulty	Have hand control repaired.
Supply hoses leaking or loose	Check connections
Cross section of the line too small	Use line with sufficient cross-section.
Brake does not release fully	Bring the inlet pressure to the required value, check the brake piston seal and replace the seal if necessary. Check the setting of the brake piston (see spare parts list).
Brake lining worn	Replace brake lining.
Motor cover bolts loose	Tighten the bolts.
Motor vanes worn	Replace motor vanes.
Motor has run dry.	Lubricate motor, check oiler.
Silencer is clogged	Replace or clean silencer elements, improve air quality if necessary.

EXCESSIVE RUNNING ON DURING BRAKING

Possible cause	Remedy
----------------	--------

Brake disc and/ or brake piston worn	Replace brake disc and/or brake piston.
--------------------------------------	---

LOUD NOISE AT THE CHAIN SPROCKET OR GEARBOX

Possible cause	Remedy
----------------	--------

Chain dry	Lubricate the chain. Check wear.
-----------	----------------------------------

Chain sprocket worn	Replace chain sprocket, check chain guide and replace if necessary.
---------------------	---

Chain worn	Replace chain with a new JDN chain.
------------	-------------------------------------

Wrong chain drawn in	Identify chain and replace with JDN chain if necessary.
----------------------	---

Defective gearbox / bearing	Have product repaired.
-----------------------------	------------------------

LIFTING AND LOWERING SPEED DECLINES OR ENGINE STOPS WITH HIGHER LIFTING HEIGHTS

Possible cause	Remedy
----------------	--------

Brake piston setting too tight	Correct adjustment of brake piston. At high ambient temperatures, perform adjustment with the device warmed up accordingly.
--------------------------------	---

Brake opening pressure too low grinding brake	Check compressed air supply
--	-----------------------------

Undersized compressor	Check compressed air supply
-----------------------	-----------------------------

A. Technical data

	metric	anglo-american
Load capacity	25 t	27.5 tn.sh.
Number of chain strands	2	
Weight with standard lift (3m (10ft)) and control	550 kg	1213 lbs
Chain dimension	23,5 x 66 mm	
Weight of chain	12,2 kg/m	8.2 lbs/ft
Air pressure	6 bar	85 psi
Air consumption at lifting with nominal load	6,5 m ³ /min	230 cfm
Air consumption at lowering with nominal load	2,9 m ³ /min	102 cfm
Hose connection	G 1 1/2	
Hose dimension (∅inside)	35 mm	1 1/2 inch
Motor output lifting motor	6,3 kW	
Lifting speed with nominal load	1,25 m/min	4.1 ft/min
Lifting speed without load	2.4 m/min	7,9 ft/min
Lowering speed at nominal load	2,8 m/min	9.2 ft/min
Noise level at lifting with nominal load	78 dB(A)	
Noise level at lowering with nominal load	82 dB(A)	

DIMENSIONS

B. Dimensions

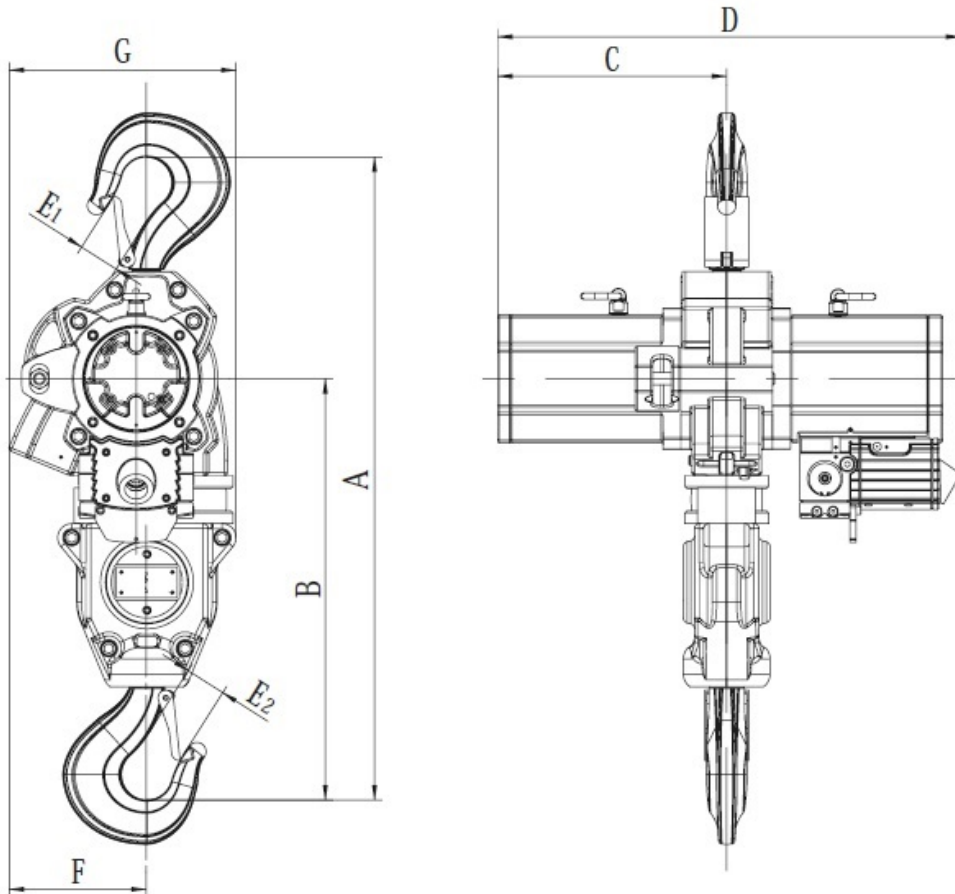

	mm	inch
A	1260	49.6
B	827	32.6
C	450	17.7
D	900	35.4
E1	75	3.0
E2	75	3.0
F	270	10.6
G	445	17.5